

# GOBOTOP MINI PROJECTOR 230 V – SPECIFICATIONS



item:..... GoboTop Mini Projector 230 V  
 material:..... heat-resistant plastic / stainless steel  
 weight: ..... 580 g  
 on- / off-switch: ..... for stand-by  
 environmental conditions:..... for dry indoor environments only  
 ambient temperature:..... 0 – 30° C  
 light source: ..... 50 W / 12 V MR16 halogen lamp  
 socket:..... GU 5.3  
 beam angle:..... 24°  
 average lifetime of the lamp:..... 5,000 hours  
 colour temperature:..... 3,200 K  
 recommended projection distance in normal room light: ..... 1.5 m / 5 ft  
 recommended projection distance in darkness: ..... 3.0 m / 10 ft  
 programmable dimmer:..... can be activated, 6 interval levels available  
 gobo size / image size: ..... Ø 37.5 mm / Ø 20 mm  
 input voltage: ..... 220 - 240 V AC, 50 / 60 Hz  
 power consumption:..... 56 W  
 power factor: ..... 0.99 cos. φ  
 power consumption in stand-by : ..... 2 W  
 electrical protection:..... II  
 ingress protection rating: ..... IP 20  
 item number: ..... 09927620 – black, 09927630 – silver



*We reserve the right to make technical and optical modifications. Our general terms and conditions apply.*

## Dimensions

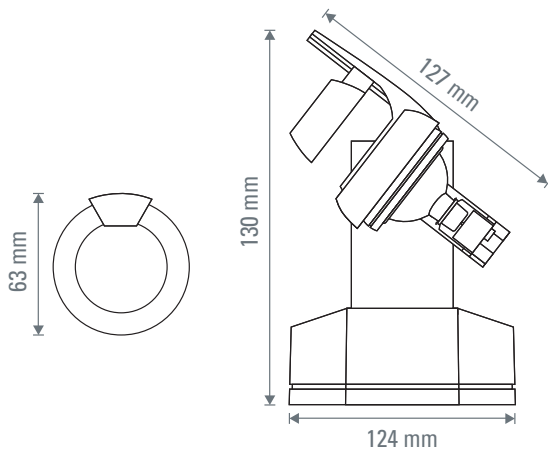

## Projection Size

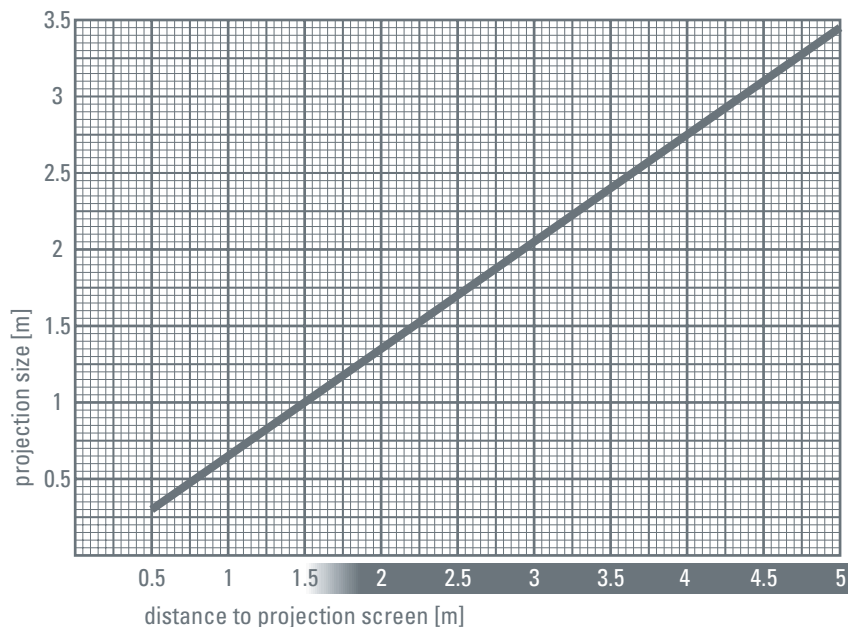

### Ready for use immediately!

Unpack it, mount it and just project! GoboTop Mini Projector for close range is ready for use and causes a sensation. The system can be freely arranged or mounted on ceilings and walls. The motifs can be changed quickly and easily.

### Light effects attract attention.

GoboTop Mini Projector is equipped with a programmable dimmer which enables animated effects. In six selectable interval stages the projected motif is faded in and out.

### Components:

Standard series with 50 W MR16 halogen lamp and integrated transformer. The machine is ready to plug in and run. Required accessories: glass gobo with individually designed Motif.

**derksen**<sup>®</sup>  
lichttechnik

Derksen Lichttechnik GmbH  
Sauerlandstraße 5  
45889 Gelsenkirchen  
Germany

Tel.: +49 (0)209 / 9 80 70 0  
Fax: +49 (0)209 / 9 80 70 60

info@derksen.de  
www.derksen.de