

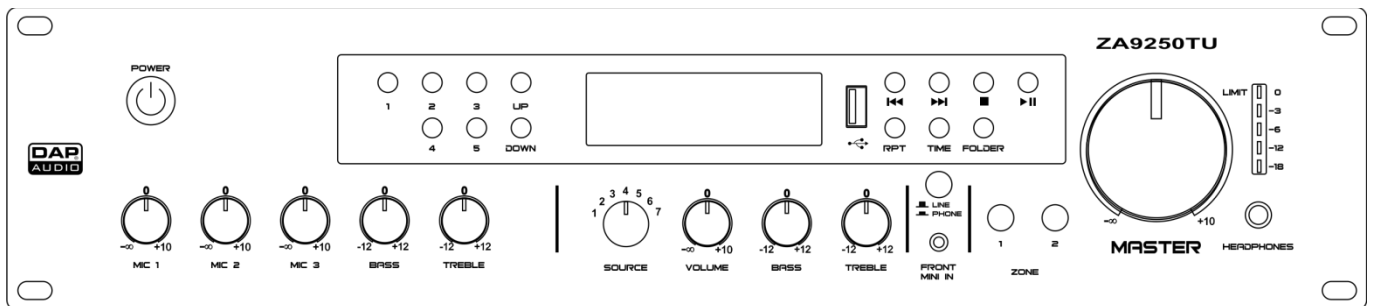

MANUAL



ENGLISH

ZA-9120TU

V1

Ordercode: D6153

Table of contents

Warning	2
Safety Instructions.....	2
Operating Determinations	4
Connection with the mains	4
Return Procedure	4
Claims.....	4
Description of the device	5
Frontside	6
Backside	8
Tuner.....	12
Audio Player	13
Installation	14
Set Up and Operation	14
Connecting Inputs.....	14
Operating the Tuner	14
Searching for Radio Stations.....	14
Tuning	14
Storing a Radio Station in Memory	15
Operating the Audio Player	15
Selecting Tracks	15
Starting/Pausing Playback	15
Stopping Playback	15
Repeat Function.....	15
Selecting Folders and Tracks	16
Playlist (PGM)	16
Connecting Outputs	17
Low Impedance Outputs	17
High Impedance Outputs	17
Connection Cables	18
Maintenance	19
Replacing the Fuse.....	19
Troubleshooting	19
Product Specifications	20
Dimensions	21
Notes	22

Warning



**For your own safety, please read this user manual carefully
before your initial start-up!**



Unpacking Instructions

Immediately upon receiving this product, carefully unpack the carton and check the contents to ensure that all parts are present, and have been received in good condition. Notify the dealer immediately and retain packing material for inspection if any parts appear damaged from shipping or the carton itself shows signs of mishandling. Save the carton and all packing materials. In the event that a device must be returned to the factory, it is important that the device is returned in the original factory box and packing.

Your shipment includes:

- DAP Audio ZA-9120TU
- FM Antenna
- IEC power cable – 1,5 m
- User manual

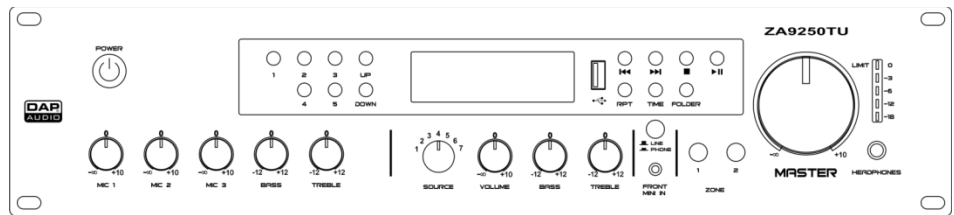

CAUTION!
Keep this device away from rain and moisture!
Unplug mains lead before opening the housing!



Safety Instructions

Every person involved with the installation, operation and maintenance of this system has to:

- be qualified
- follow the instructions of this manual



CAUTION! Be careful with your operations.
**With a dangerous voltage you can suffer
a dangerous electric shock when touching the wires!**



Before you initial start-up, please make sure that there is no damage caused by transportation. Should there be any, consult your dealer and do not use the system.

To maintain perfect condition and to ensure a safe operation, it is absolutely necessary for the user to follow the safety instructions and warning notes written in this manual.

Please consider that damages caused by manual modifications to the system are not subject to warranty.

This system contains no user-serviceable parts. Refer servicing to qualified technicians only.

IMPORTANT:

The manufacturer will not accept liability for any resulting damages caused by the non-observance of this manual or any unauthorized modification to the system.

- Never let the power cord come into contact with other cables! Handle the power cord and all connections with the mains with particular caution!
- Never remove warning or informative labels from the unit.
- Never use anything to cover the ground contact.
- Never leave any cables lying around.
- Do not insert objects into air vents.
- Do not connect this system to a dimmerpack.
- Do not switch the system on and off in short intervals, as this would reduce the system's life.
- Do not open the device and do not modify the device.
- Do not drive the inputs with a signal level bigger, than required to drive the equipment to full output.
- Do not plug mics into the console (or stagebox) while phantom power is on. Also mute the monitor / Pa system when turning phantom power on or off. Allow the system to adjust for a couple of seconds, before setting the input gains.
- Only use system indoors, avoid contact with water or other liquids.
- Avoid flames and do not put close to flammable liquids or gases.
- Always disconnect power from the mains, when system is not used. Only handle the power cord by the plug. Never pull out the plug by tugging the power cord.
- Always operate the unit with the AC ground wire connected to the electrical system ground.
- Make sure you do not use the wrong kind of cables or defective cables.
- Make sure that the signals into the mixer are balanced, otherwise hum could be created.
- Make sure you use DI boxes to balance unbalanced signals; All incoming signals should be clear.
- Make sure that the available voltage is not higher than stated on the rear panel.
- Make sure that the power cord is never crimped or damaged. Check the system and the power cord from time to time.
- Please turn off the power switch, when changing the power cord or signal cable, or select the input mode switch.
- Extreme frequency boosts in connection with a high input signal level may lead to overdriving your equipment. Should this occur, it is necessary to reduce the input signal level by using the INPUT control.
- To emphasize a frequency range, you do not necessarily have to move its respective control upward; try lowering surrounding frequency ranges instead. This way, you avoid causing the next piece of equipment in your sound path to overdrive. You also preserve valuable dynamic reserve ("headroom").
- Avoid ground loops! Always be sure to connect the power amps and the mixing console to the same electrical circuit to ensure the same phase!
- If system is dropped or struck, disconnect mains power supply immediately. Have a qualified engineer inspect for safety before operating.
- If the system has been exposed to drastic temperature fluctuation (e.g. after transportation), do not switch it on immediately. The arising condensation water might damage your system. Leave the system switched off until it has reached room temperature.
- If your Dap Audio device fails to work properly, discontinue use immediately. Pack the unit securely (preferably in the original packing material), and return it to your Dap Audio dealer for service.
- Repairs, servicing and electric connection must be carried out by a qualified technician.
- For replacement use fuses of same type and rating only.
- WARRANTY: Till one year after date of purchase.

Operating Determinations

This system is not designed for permanent operation. Consistent operation breaks will ensure that the system will serve you for a long time without defects.

If this system is operated in any other way, than the one described in this manual, the product may suffer damages and the warranty becomes void.

Any other operation may lead to dangers like short-circuit, burns, electric shock, etc.

You endanger your own safety and the safety of others!

Improper installation can cause serious damage to people and property!

Connection with the mains

Connect the device to the mains with the power-plug.

Always pay attention, that the right color cable is connected to the right place.

International	EU Cable	UK Cable	US Cable	Pin
L	BROWN	RED	YELLOW/COPPER	PHASE
N	BLUE	BLACK	SILVER	NEUTRAL
	YELLOW/GREEN	GREEN	GREEN	PROTECTIVE GROUND

Make sure that the device is always connected properly to the earth!

Improper installation can cause serious damage to people and property!

 Return Procedure 

Returned merchandise must be sent prepaid and in the original packing, call tags will not be issued. Package must be clearly labeled with a Return Authorization Number (RMA number). Products returned without an RMA number will be refused. Highlite will not accept the returned goods or any responsibility. Call Highlite 0031-455667723 or mail offersales@highlite.nl and request an RMA prior to shipping the fixture. Be prepared to provide the model number, serial number and a brief description of the cause for the return. Be sure to properly pack fixture, any shipping damage resulting from inadequate packaging is the customer's responsibility. Highlite reserves the right to use its own discretion to repair or replace product(s). As a suggestion, proper UPS packing or double-boxing is always a safe method to use.

Note: If you are given an RMA number, please include the following information on a piece of paper inside the box:

- 01) Your name
- 02) Your address
- 03) Your phone number
- 04) A brief description of the symptoms

Claims

The client has the obligation to check the delivered goods immediately upon delivery for any short-comings and/or visible defects, or perform this check after our announcement that the goods are at their disposal. Damage incurred in shipping is the responsibility of the shipper; therefore the damage must be reported to the carrier upon receipt of merchandise.

It is the customer's responsibility to notify and submit claims with the shipper in the event that a fixture is damaged due to shipping. Transportation damage has to be reported to us within one day after receipt of the delivery.

Any return shipment has to be made post-paid at all times. Return shipments must be accompanied with a letter defining the reason for return shipment. Non-prepaid return shipments will be refused, unless otherwise agreed in writing.

Complaints against us must be made known in writing or by fax within 10 working days after receipt of the invoice. After this period complaints will not be handled anymore.

Complaints will only then be considered if the client has so far complied with all parts of the agreement, regardless of the agreement of which the obligation is resulting.

Description of the device

Features

The DAP ZA-9120TU is a 120W, 100V mixer amplifier with 7 selectable sources, 3 microphone inputs and 2 zones. All microphone inputs are equipped with phantom power and can also be selected as line input. The integrated speech filter can be applied to improve the audibility. The amplifier is equipped with 3 dedicated line inputs on the backside and a special easy access line/phone front input to connect mp3 players or mobile devices. It has a built-in USB audio player and tuner with a large LCD display, which shows the active source, tuner information and ID3 tags. The built-in FM tuner can store up to 10 presets. The other worth mentioning features are priority, chime with adjustable level, emergency input, ducking level control, loop through connection and the output which can be set as line output, music only or microphone only. Both zones have their own line outputs, to connect extra amplifiers and extend the PA system. The ZA-9120TU is the ideal, easy to use, one-in-all solution for medium size PA systems.

Outputs

- Power consumption: 120W
- Zones: 2
- 100V & 8Ω: Terminals
- Line output: XLR
- Loop through: RCA
- Headphones: 6,3 mm jack

Inputs

- 3 x Mic/Line: XLR/jack combo & terminals
- 3 x Line: RCA
- Front input: 3,5 mm jack

Media player – USB

- Source: 2 x USB type A, front/back
- Supported extensions: MP3, WAV
- Format: FAT32 up to 32GB
- Playback: Program, Repeat, Continuous

Media player - Tuner

- FM band: 87,5 – 108MHz
- Presets: 10
- Antenna: 75Ω

Features

- Speech filter: -3dB, 300Hz 6dB/oct
- Phantom power: 18V
- Tone control: Bass 100 Hz, treble 12 KHz, +/- 12dB
- Chime: adjustable volume
- Ducking: adjustable suppression
- PTT: Mic input 1
- VOX: Mic input 2
- Telephone input: override all, terminal

General

- Power supply: 230V AC, 50 Hz
- Back-up power supply: 24V DC
- Power consumption: 250W
- Power connection: IEC power connector
- Fuse: T5AL/250V
- Dimensions: 330 x 482 x 95 mm (LxWxH)
19" x 2HE (LxH)
- Weight: 9,3 kg

Frontside

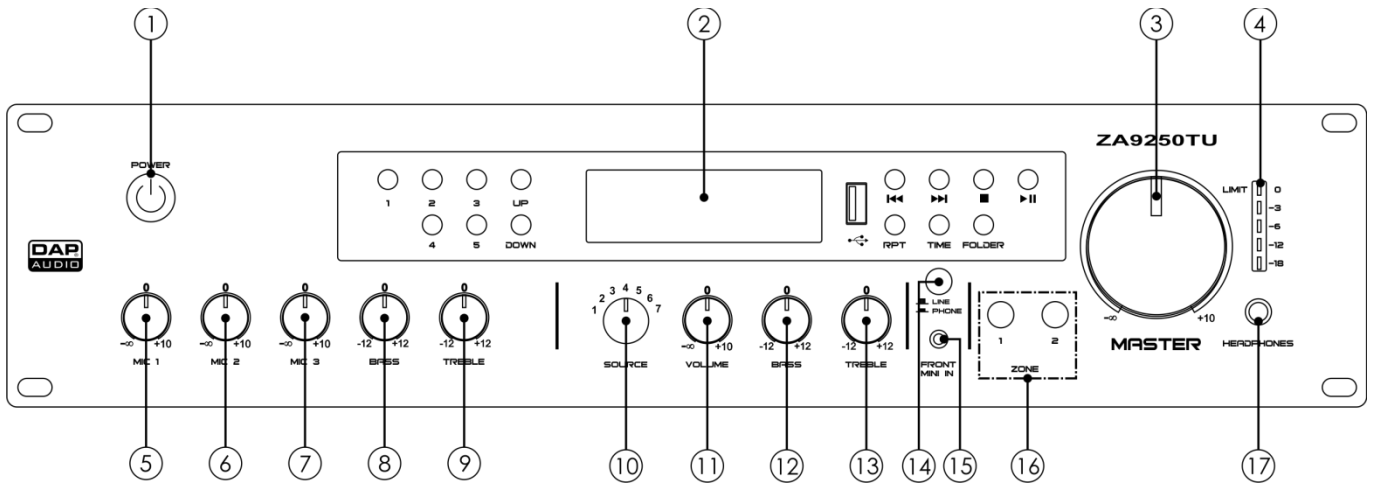

Fig. 01

- ① **Power switch ON/OFF**
Press the button to switch the device ON/OFF.
- ② **Tuner/audio player**
See section Tuner, page 12 and section Audio Player, page 13.
- ③ **Master control**
Turn the control to adjust the master volume level, according to your preference.
- ④ **VU meter**
The clip LED indicates peak levels at the output of the amplifier. If the red LED frequently blinks or lights continuously, the output is likely to enter clipping. If this happens, we strongly suggest turning the **master control (03)** to the left, to decrease the master volume.
- ⑤ **Mic 1 level control**
Turn the control to adjust the volume level for input Mic 1.
- ⑥ **Mic 2 level control**
Turn the control to adjust the volume level for input Mic 2.
- ⑦ **Mic 3 level control**
Turn the control to adjust the volume level for input Mic 3.
- ⑧ **Bass control**
Turn the control to adjust the bass level of Mic inputs 1-3.
- ⑨ **Treble control**
Turn the control to adjust the treble level of Mic inputs 1-3.

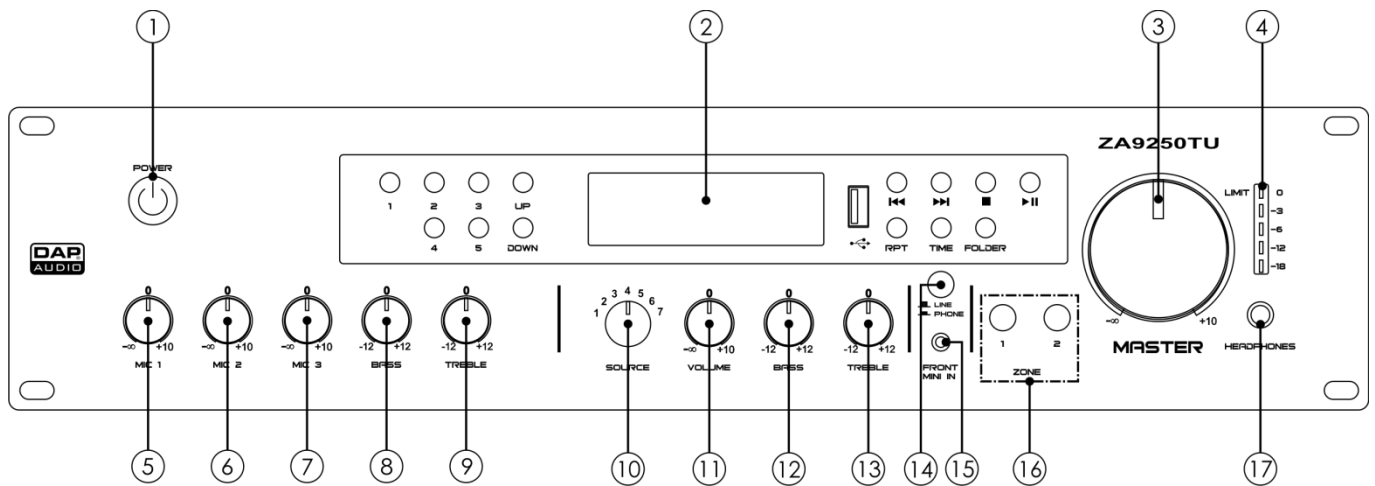

Fig. 02

10 Source selector

Turn the control to set the desired signal source or the built-in audio player/tuner. The available sources are:

- 1. Tuner
- 2. USB front
- 3. USB back
- 4. CD
- 5. Video
- 6. Aux
- 7. Phone/MP3

11 Volume control

Turn the control to adjust the volume level of the selected source.

12 Bass control

Turn the control to adjust the bass level of the selected source.

13 Treble control

Turn the control to adjust the treble level of the selected source.

14 Line/phone switch

Press the button to switch between level input or phone level input. The phone level adjusts the input sensitivity into the correct level for MP3 players, smartphones or tablets. Now you can playback your MP3 devices directly without signal loss.

15 Front IN

Unbalanced stereo 3,5 mm mini jack aux input for connecting a line/phones level device. Press the **line/phone (14)** switch to set up this input for connecting either headphone or line level output devices.

16 1-2 zone buttons

Press the buttons to activate/deactivate 1-2 zone speaker outputs and line level outputs.

17 Headphones 6,3 mm jack IN

Use this connector to connect 6,3 mm jack headphones.

Backside

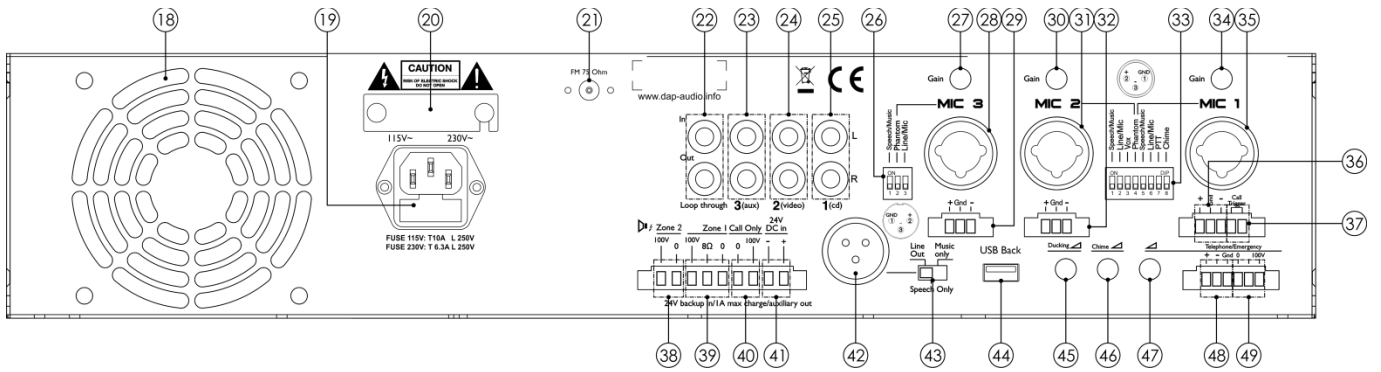

Fig. 03

- 18 Cooling fan**
Do not obstruct the air inlet.
- 19 IEC power connector 230V AC + fuse T5AL/250V**
Connect the device to the appropriate power supply.
- 20 AC selector**
Before connecting your ZA-9120TU to the mains, make sure that the AC selector is set to the proper voltage which is used in your country. In case of doubt, consult a technician.
- 21 75Ω FM antenna connector**
Connect your FM antenna to this connector.
- 22 Loop through RCA IN/OUT**
Loop through input and output connections allow external sound processing equipment to be connected between the preamplifier and the power amplifier stages.
- 23 Aux – RCA IN**
Connect an auxiliary signal source. The **source selector (10)** must be set to **6**.
- 24 Video – RCA IN**
Connect a video signal source. The **source selector (10)** must be set to **5**.
- 25 CD – RCA IN**
Connect a video signal source. The **source selector (10)** must be set to **4**.
- 26 Mic 3 function DIP switches**
Moving the DIP switches to ON/OFF allows you to set up combo input 3. The available options are:

 - Speech/Music
 - Phantom
 - Line/Mic

Speech/Music: If set to ON, the device will cut off the lower frequencies of the input signal, which will improve speech audibility. If set to OFF, the low frequencies will not be cut off.

Phantom power: If set to ON, the device will provide power to condenser microphones.

Line/Mic: If set to ON, the input sensitivity will be set for line inputs. If set to OFF, the input sensitivity will be set for microphone level.

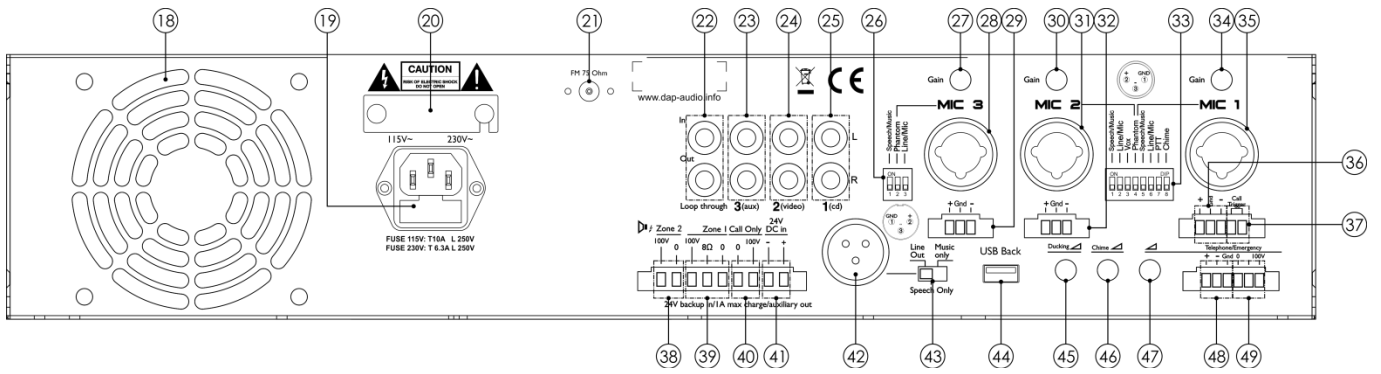

Fig. 04

- 27 **Gain level control – Mic 3**
Adjust input level for Mic 3.
- 28 **Combo input – Mic 3**
Combo input for Mic 3. Accepts balanced or unbalanced inputs.
- 29 **Mic 3 terminal connector IN**
Terminal input for Mic 3. Accepts balanced or unbalanced inputs.
- 30 **Gain level control – Mic 2**
Adjust input level for Mic 2.
- 31 **Combo input – Mic 2**
Combo input for Mic 2. Accepts balanced or unbalanced inputs.
- 32 **Mic 2 terminal connector IN**
Terminal input for Mic 2. Accepts balanced or unbalanced inputs.
- 33 **Mic 1-2 function DIP switches**
Moving the DIP switches to ON/OFF allows you to set up combo inputs 1-2. The available options are:

 - Speech/Music
 - Line/Mic
 - Phantom
 - PTT
 - Chime
 - Vox

Speech/Music: If set to ON, the device will cut off the lower frequencies of the input signal, which will improve speech audibility. If set to OFF, the low frequencies will not be cut off.

Line/Mic: If set to ON, the input sensitivity will be set for line inputs. If set to OFF, the input sensitivity will be set for microphone level.

Phantom power: If set to ON, the device will provide power to condenser microphones.

PTT (push to talk): If set to ON, this input will be muted when push to talk contact is open. When push to talk contact is closed, then this input will be available for speech. Also, chime function will be audible, if selected. Music and other mic/line inputs will be reduced to the level set with the ducking level control.

If set to OFF, then the PTT function will be switched off. The signal will be mixed with the other mic/line signals. Mic 1 will mix with the background music or other microphones in the selected zones.

Chime: If set to ON, chime will be audible at the beginning of an announcement. If set to OFF, chime will not be audible.

Vox: If set to ON, the background music will be suppressed to the preset ducking level, while speaking into the microphone.

③④ **Gain level control – Mic 1**

Adjust input level for Mic 1.

③⑤ **Combo input – Mic 1**

Combo input for channel 1. Accepts balanced or unbalanced inputs.

③⑥ **Mic 1 terminal connector IN**

Terminal input for Mic 1. Accepts balanced or unbalanced inputs.

③⑦ **Call Trigger terminal connector**

Connect both terminals to a trigger button in order to activate chime.

③⑧ **Zone 2 100V terminal connector**

Connect the main feed cable from your 100V speaker to the 100V terminal. Connect the common cable from your speaker to the 0 terminal.

③⑨ **Zone 1 100V/8Ω terminal connector**

If you connect a 100V speaker, connect the main feed cable to the 100V terminal and the common cable to the 0 terminal.

If you connect a low impedance speaker, then connect the main feed cable to the 8Ω terminal and the common cable to the 0 terminal.

NOTE: Do not connect the 100V and 8Ω speakers at the same time.

④⑩ **Call Only terminal connector**

Use this output as an extra zone where announcements can be heard, but not music.

④⑪ **24V DC IN terminal connector**

This input can be used in mobile applications, such as boats where 120 or 230V AC is not available or in applications that must continue to operate in case of power shortage. When a 24V DC battery is connected, the unit will operate on the supplied DC voltage. The amplifier has a built-in charger, which charges the connected battery.

④⑫ **XLR balanced connector OUT**

Use this connector to provide a dedicated output source for another device, per zone.

④⑬ **Line Out/Speech Only/Music Only**

Master output can be connected to a telephone coupler, so that callers can listen to music when they are put on hold. Move the switch to one of the 3 available options:

- Line Out
- Music Only
- Speech Only

Line Out: Set the switch to Line Out. All mixed inputs (microphone/line, emergency and music) will be audible.

Music Only: Set the switch to Music Only. Now, the **XLR balanced output (42)** becomes an extra dedicated music output source, available for another external device. The **outputs (24/25/26)** will be audible. All the other inputs, including Telephone/Emergency/100V will not be sent to the output.

Speech Only: Only microphone input will be audible at the **XLR balanced output (42)**.

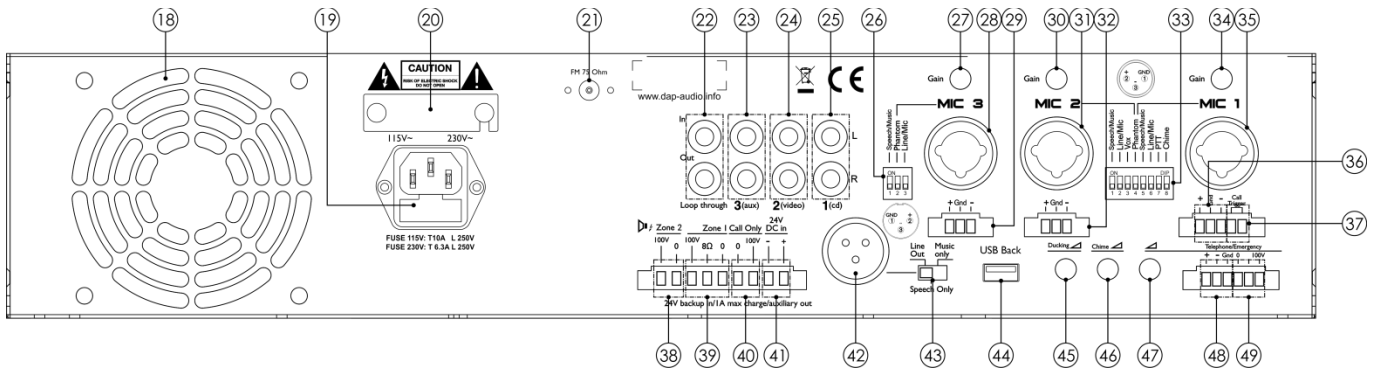

Fig. 05

- 44 USB connector A - Back**
 Use this connector to connect a USB flash drive with MP3 or WAV files.
- 45 Ducking level control**
 Ducking level control for microphone/line input 2. When someone speaks into the microphone, other sound will either be muted or suppressed, depending on the setting of the ducking level. The DIP switch "Vox" (33) should be set to ON position for this function to work.
- 46 Chime level control**
 Turn the control to adjust chime level. In chime mode, all inputs except input 1 will be muted so that it is possible to broadcast a message after the chime signal.
- 47 Telephone/Emergency level control**
 Once you have connected a telephone line or emergency alarm to the device, turn this control to receive emergency announcements or signals (such as a fire alarm). This input has absolute priority, and will overrule all inputs, when an emergency announcement or signal is received.
- 48 Telephone terminal connector**
 Use this connector to connect a telephone line. A connection to a telephone network must always be made via a telephone coupler that provides good isolation between the telephone network and the amplifier.

⚠ Do not connect a telephone line and emergency alarm source at the same time. ⚠

⚠ Never make a direct connection between the telephone network and the mixer amplifier. ⚠

- 49 Emergency terminal connector**
 Use this connector to connect an emergency alarm source.

⚠ Do not connect a telephone line and emergency alarm source at the same time. ⚠

Tuner

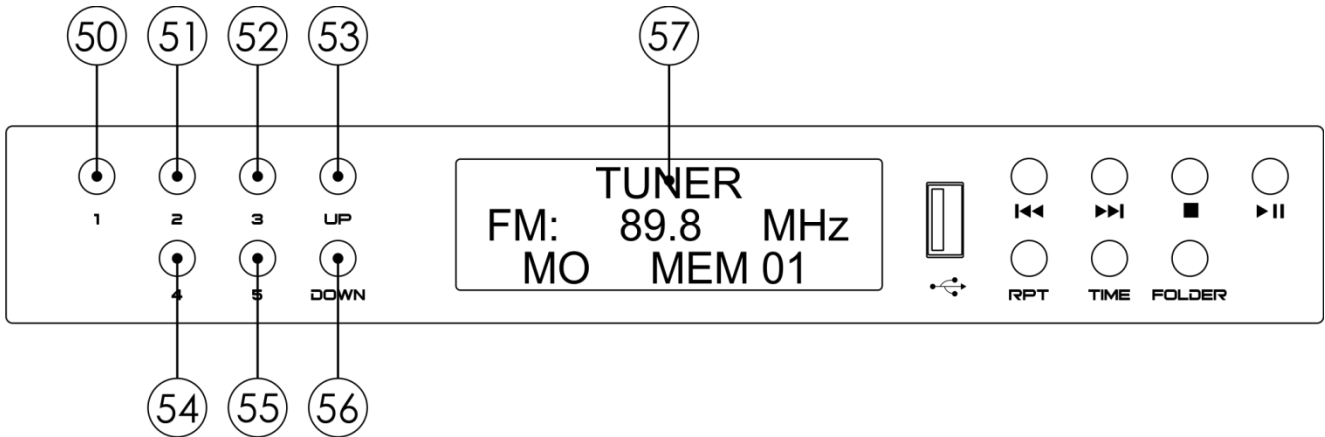

Fig. 06

- 50 Preset 1 button**
Press this button to recall preset 1.
- 51 Preset 2 button**
Press this button to recall preset 2.
- 52 Preset 3 button**
Press this button to recall preset 3.
- 53 UP button**
Press this button to select the desired station. Press and hold down the button for 2 seconds to automatically increase the FM frequency, until the radio is tuned. In order to stop the search manually, press the button again.
- 54 Preset 4 button**
Press this button to recall preset 4.
- 55 Preset 5 button**
Press this button to recall preset 5.
- 56 DOWN button**
Press this button to select the desired station. Press and hold down the button for 2 seconds to automatically decrease the FM frequency, until the radio is tuned. In order to stop the search manually, press the button again.
- 57 LCD display**
In Tuner mode, the display shows the frequency and the current preset number.

Audio Player

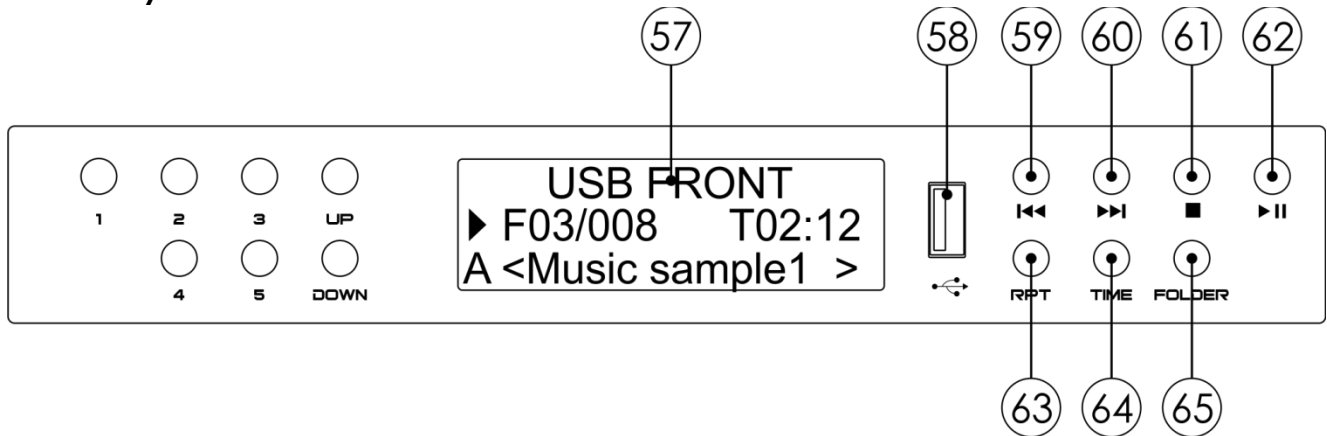

Fig. 07

- 57 LCD display**
In Audio Player mode, the display shows the current track's name and number, playback time and the current playback mode.
- 58 USB connector A - Front**
Use this connector to connect a USB flash drive with MP3 or WAV files.
- 59 I◀◀ button**
Press the button to skip backwards.
- 60 ▶▶I button**
Press the button to skip forwards.
- 61 ■ button**
Press this button to stop playback.
- 62 ▶|| button**
Press this button to start playback. Press this button again to pause playback.
- 63 Repeat button**
Press this button to choose the desired playback modes.
- 64 Time button**
Press this button to toggle between the following 2 time display modes: elapsed time and remaining time.
- 65 Folder button**
Press this button to browse through the directories on your USB flash drive or CD.

Installation

Remove all packing materials from the ZA-9120TU. Check if all foam and plastic padding is removed. Secure the equipment into a 19" rack if preferred. Connect all cables.

**Always disconnect from electric mains power supply before cleaning or servicing.
Damages caused by non-observance are not subject to warranty.**

Set Up and Operation

Before plugging the unit in, always make sure that the power supply matches the product specification voltage. Do not attempt to operate a 115V specification product on 230V power, or vice versa.

Before powering up the first time, make sure that the AC selector is set to the proper voltage!

Damage caused by connecting the amplifier to improper AC voltage is not covered by any warranty!

⚠ Always turn off and disconnect the amplifier from mains voltage before making audio connections. The attenuators should always be turned down during power-up. ⚠

Connecting Inputs

Use the jack inputs on the front panel or the XLR input connectors on the rear to supply audio signals to your DAP Audio ZA-9120TU amplifier. The jack connectors accept unbalanced audio connections while the XLR connectors accept balanced and unbalanced audio connections.

Operating the Tuner

01) Turn the **source selector (10)** to 1. The display will show:

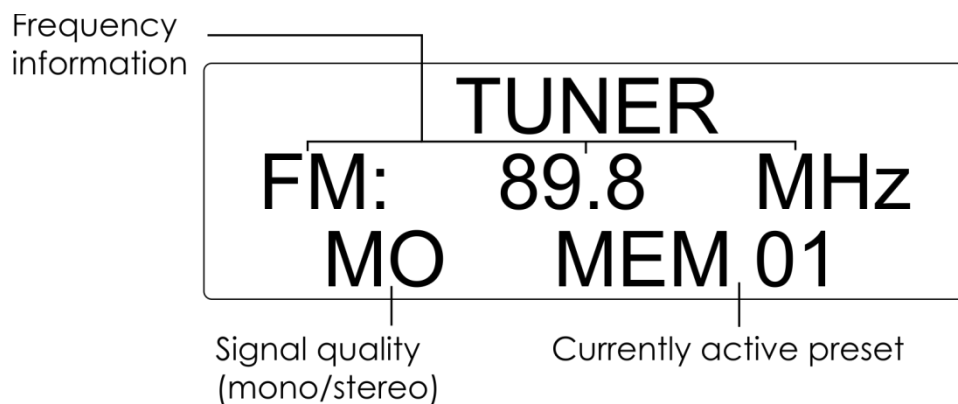

Searching for Radio Stations

- 01) Press the **UP/DOWN buttons (53/56)** to select previous/next radio station. There are 10 available radio presets.
- 02) You can also press the **preset buttons 1-5 (50/51/52/54/55)** to select one of the first 5 radio stations.

Tuning

- 01) Press and hold down the **UP/DOWN buttons (53/56)** for 2 seconds to start automatic tuning. The tuner will keep searching for a strong wavelength. Once it is found, the search will stop.
- 02) In order to fine-tune the signal quality, press the skip buttons **◀◀** and **▶▶** to move backwards or forwards, until the quality of the signal is good.

Storing a Radio Station in Memory

- 01) If you want to save a newly found radio station as one of the first 4 presets, press and hold down one of the **preset buttons 1-4 (50/51/52/54)**. Release the button as soon as the desired preset number appears on the display.
- 02) If you want to save a newly found radio station as one of the remaining presets 5-10, follow the examples below.

Example 1: You want to save a newly found radio station on preset 4.

- 01) Press and hold down the **preset button 4 (54)**.
- 02) Release the button as soon as the preset number **04** appears on the display.

Example 2: You want to save a newly found radio station on preset 8.

- 01) Press and hold down the **preset button 5 (55)** until the preset number **05** on the display **starts blinking**.
- 02) Now you have 5 seconds to press the **preset button 3 (52)**, because **5+3=8**.
- 03) The radio station is now saved on preset 8.
- 04) In step 2, if you do not press any button during the first 5 seconds, your radio station will be saved on preset 5.

Operating the Audio Player

- 01) Connect the desired music source to the amplifier.
- 02) Turn the **source selector (10)** to choose the appropriate music source (see Source selector, page 7).
- 03) The display will show:

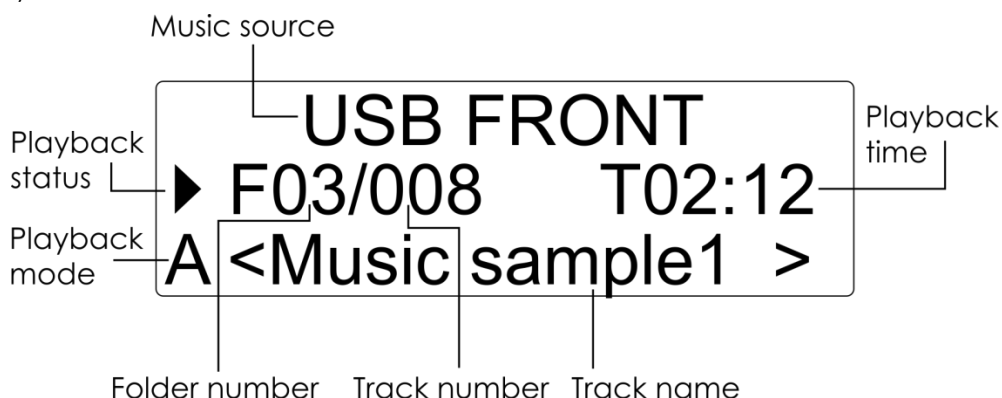

Selecting Tracks

- 01) Press the skip buttons **◀◀** and **▶▶** to select previous/next track. The selected track's name and time data will appear on the display.
- 02) Press and hold down the skip buttons **◀◀** and **▶▶** to rewind/fast-forward the selected track.

Starting/Pausing Playback

- 01) Once you have selected the desired track, press the **▶ ||** button to start playback.
- 02) Press the **▶ ||** button again to pause playback.

Stopping Playback

- 01) Press the **■** button to stop playback.

Repeat Function

- 01) Press repeatedly the **Repeat button (63)** to toggle between the following playback modes:
 - **A** – Once the final track from a given folder has passed, the player will skip to the following folder, starting playback from the first track on the list.
 - **F** – Once the final track from the selected folder has passed, the audio player will replay the whole folder, starting from the first track on the list.
 - **S** – Single track mode. The player will repeat the selected track. Each press of the skip buttons **◀◀** and **▶▶** will cause the player to return to the beginning of the selected track.
- 02) When the display shows no playback mode indication, once the final track from the selected folder has passed, the player will stop playback.

Selecting Folders and Tracks

01) While playback is active, press the **Folder button (65)**. The display will show:

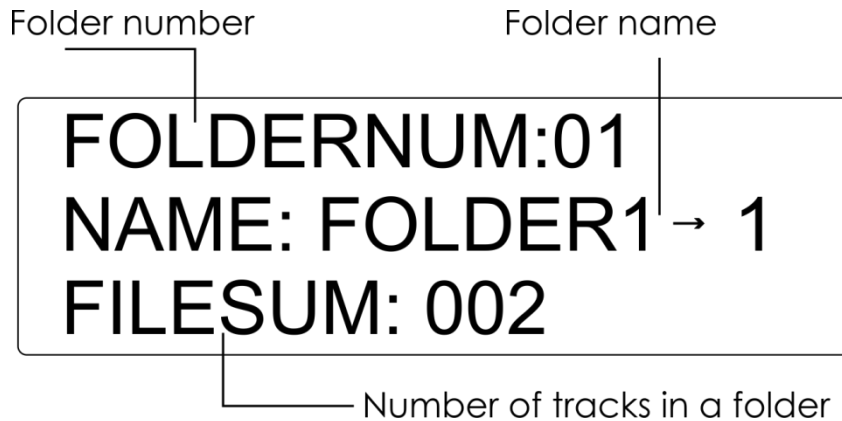

02) Press the **◀◀** and **▶▶** buttons to select the desired folder.

03) Press the **▶||** button to enter the selected folder/track. The display will show:

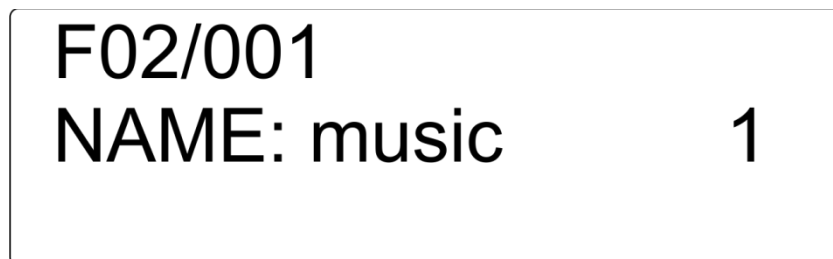

04) Press the **◀◀** and **▶▶** buttons to select the desired folder/track within the folder.

05) Press the **▶||** button to play/enter the desired track/subfolder.

Playlist (PGM)

01) When you are in a folder containing tracks, press the **◀◀** and **▶▶** buttons to choose the desired track.

02) Press the **Time button (64)** to add the track to the playlist.

03) Repeat steps 1-2 for the desired amount of times, in order to add more tracks.

04) Press the **▶||** button to start the previously created playlist.

05) Press the **◀◀** and **▶▶** buttons to toggle through the tracks from the created playlist.

06) Press the **■** button to stop playback and discard the playlist. The device will return to normal playback mode.

Connecting Outputs

Speakers are connected by means of terminal connectors. See the examples below.

Low Impedance Outputs

You can use as many speakers as you want as long as the total impedance matches the amplifiers output.

Example 1: Using the 8Ω output with an 8Ω speaker.

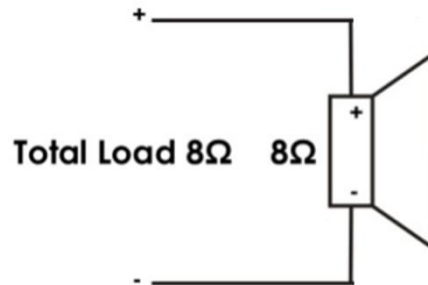

Fig. 08

Example 2: Using the 8Ω output with two 4Ω speakers.

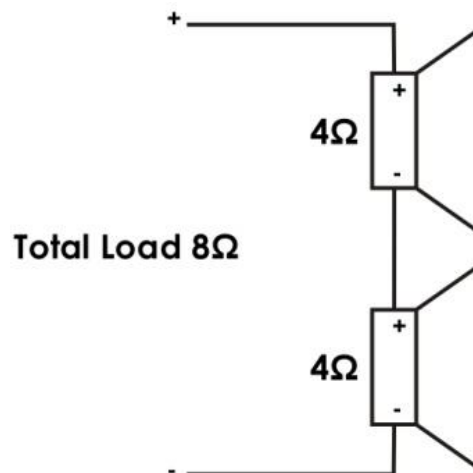

Fig. 09

⚠ In a low impedance system, the total speaker load should always match the amplifier's impedance, in order not to overload the amplifier. The total speaker power should be at least equal to the power of the amplifier, to avoid speaker damage. ⚠

High Impedance Outputs

While using either the 70V outputs or the 100V outputs, note that all speakers **should be wired in parallel**.

⚠ The total power of all speakers summed together should never exceed the total power of the amplifier in a 70V or a 100V system! ⚠

Connection Cables

Take care of your cables, always holding them by the connectors and avoiding knots and twists when coiling them: This gives the advantage of increasing their life and reliability. Periodically check your cables. A great number of problems (faulty contacts, ground hum, discharges, etc.) are caused entirely by using unsuitable or faulty cables.

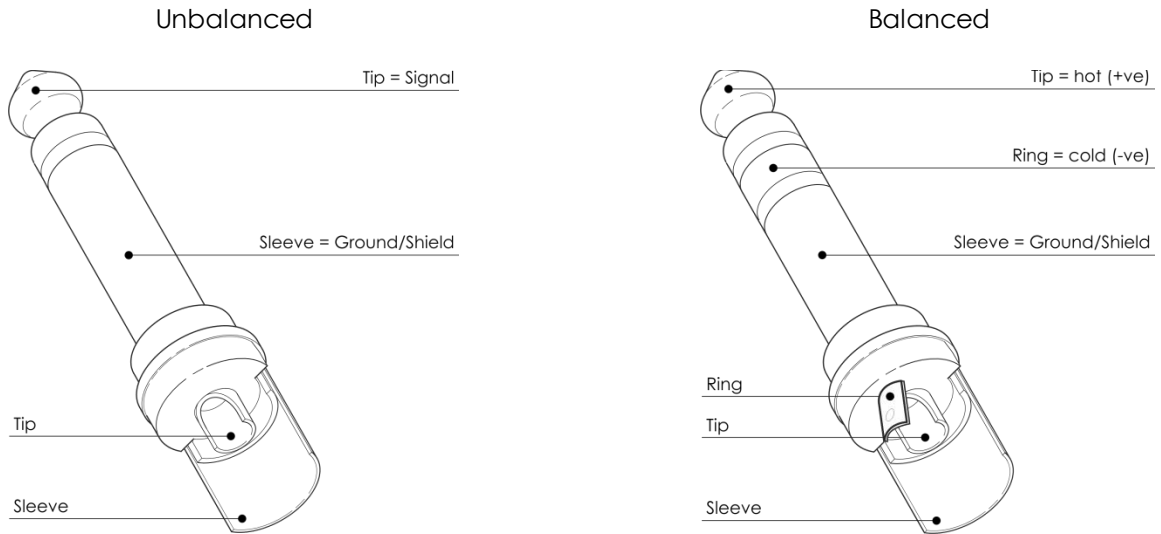

For these applications the unit provides 1/4" TRS and XLR connectors to easily interface with most professional audio devices. Follow the configuration examples below for your particular connection.

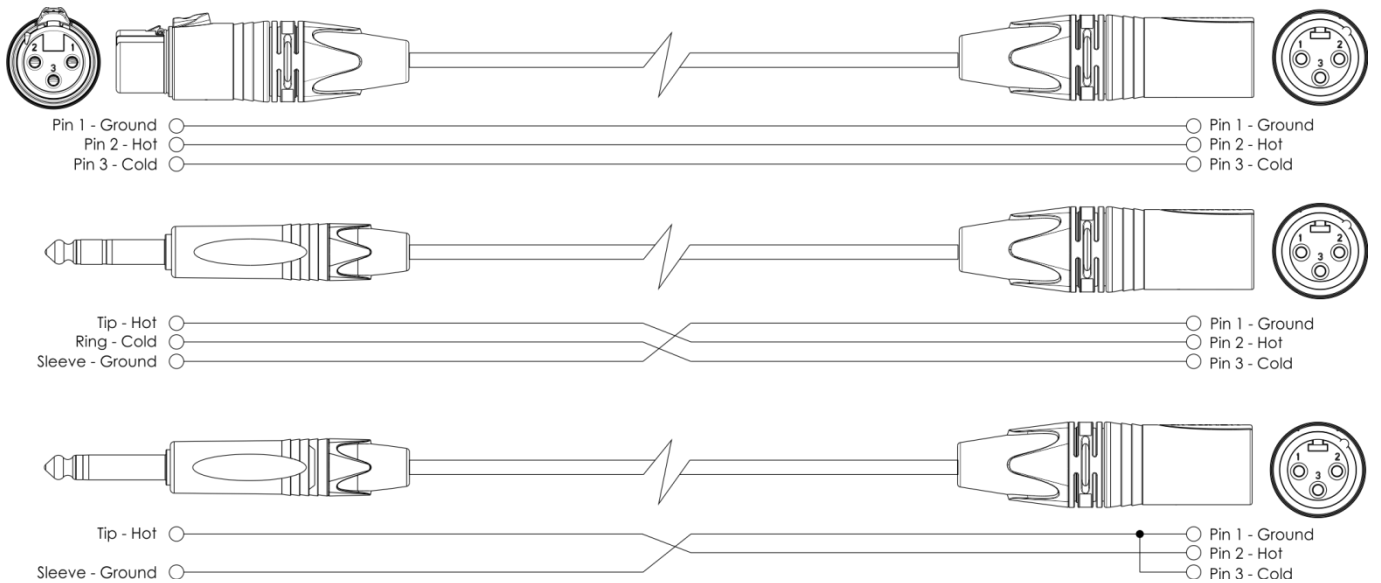

Maintenance

The DAP Audio ZA-9120TU requires almost no maintenance. However, you should keep the unit clean. Disconnect the mains power supply, and then wipe the cover with a damp cloth. Do not immerse in liquid. Do not use alcohol or solvents.

Keep connections clean. Disconnect electric power, and then wipe the audio connections with a damp cloth. Make sure connections are thoroughly dry before linking equipment or supplying electric power.

Replacing the Fuse

Power surges, short-circuit or inappropriate electrical power supply may cause a fuse to burn out. If the fuse burns out, the product will not function whatsoever. If this happens, follow the directions below.

- 01) Unplug the unit from electric power source.
- 02) Insert a screwdriver into the slot in the fuse cover. Gently pry up the fuse cover. The fuse will come out.
- 03) Remove the used fuse. If brown or unclear, it is burned out.
- 04) Insert the replacement fuse into the holder where the old fuse was. Reinsert the fuse cover. Be sure to use a fuse of the same type and specification. See the product specification label for details.

Troubleshooting

DAP Audio ZA-9120TU

This troubleshooting guide is meant to help solve simple problems. If a problem occurs, carry out the steps below in sequence until a solution is found. Once the unit operates properly, do not carry out following steps.

- 01) If the device does not operate properly, unplug the device.
- 02) Check power from the wall, all cables, connections, etc.
- 03) Replace the fuse. See page 19 for replacing the fuse.
- 04) If all of the above appears to be O.K., plug the unit in again.
- 05) If nothing happens after 30 seconds, unplug the device.
- 06) Return the device to your DAP Audio dealer.

Product Specifications

Outputs

- Power consumption: 120W
- Zones: 2
- 100V & 8Ω: Terminals
- Line output: XLR
- Loop through: RCA
- Headphones: 6,3 mm jack

Inputs

- 3 x Mic/Line: XLR/jack combo & terminals
- 3 x Line: RCA
- Front input: 3,5 mm jack

Media player – USB

- Source: 2 x USB type A, front/back
- Supported extensions: MP3, WAV
- Format: FAT32 up to 32GB
- Playback: Program, Repeat, Continuous

Media player - Tuner

- FM band: 87,5 – 108MHz
- Presets: 10
- Antenna: 75Ω

Features

- Speech filter: -3dB, 300Hz 6dB/oct
- Phantom power: 18V
- Tone control: Bass 100 Hz, treble 12 KHz, +/- 12dB
- Chime: adjustable volume
- Ducking: adjustable suppression
- PTT: Mic input 1
- VOX: Mic input 2
- Telephone input: override all, terminal

General

- Power supply: 230V AC, 50 Hz
- Back-up power supply: 24V DC
- Power consumption: 250W
- Power connection: IEC power connector
- Fuse: T5AL/250V
- Dimensions: 330 x 482 x 95 mm (LxWxH)
19" x 2HE (LxH)
- Weight: 9,3 kg

Design and product specifications are subject to change without prior notice.



Website: www.Dap-audio.info

Email: service@highlite.nl

Dimensions

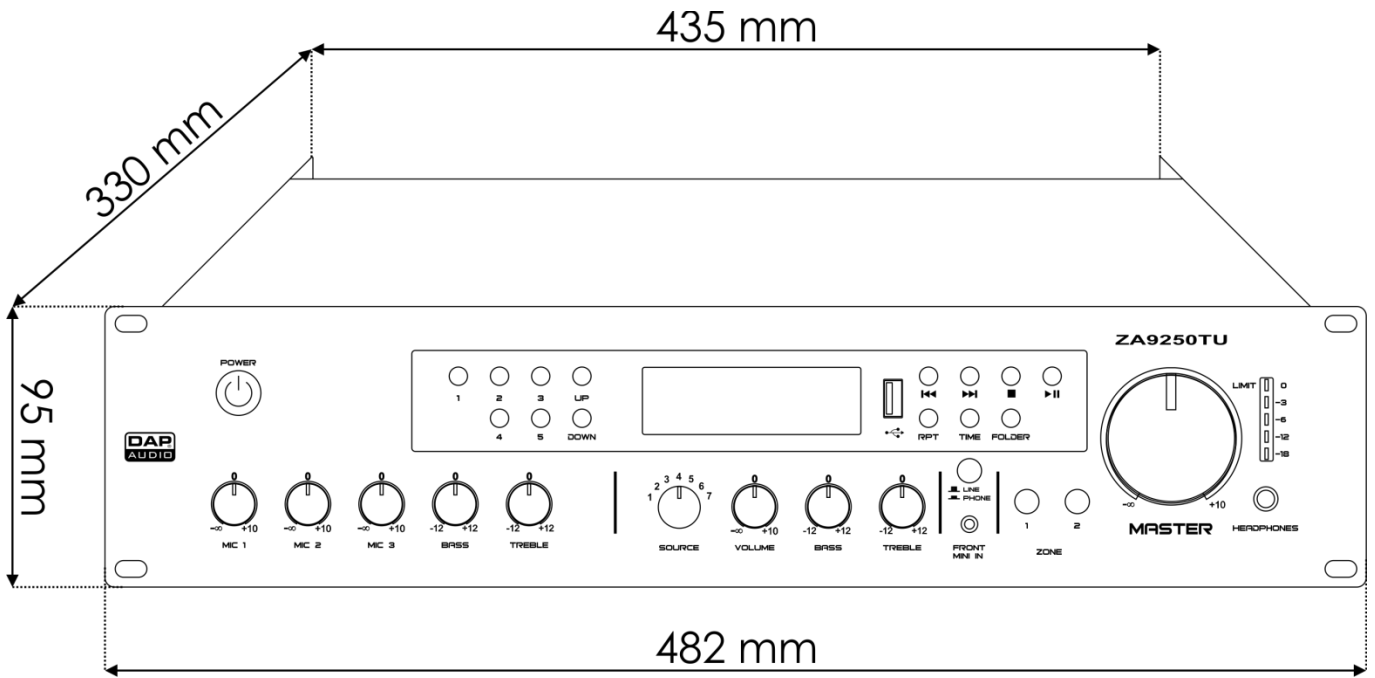



©2016 DAP Audio