

INTUSONIC

INTUSONIC

INTUSONIC is a brand of
Universal Technical Industries Co. Ltd.

Concept, Design & Distribution by

Adelto Industries Limited

Unit 4 Britannia Business Park
Comet Way, Southend-on-Sea
Essex, SS2 6GE, United Kingdom
www.adelto.com / sales@adelto.com

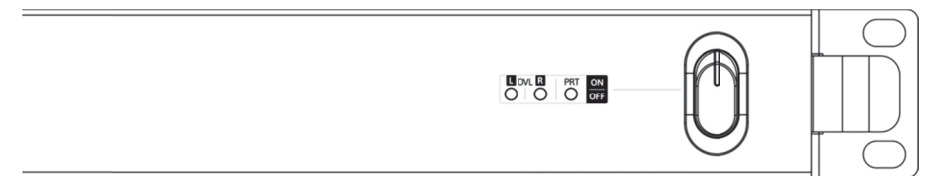

INTUFORCE 2SDL160

Stereo Audio Utility Amplifier

Welcome

Thank you for choosing INTUSONIC for your sound system. To make sure that this product meets your expectations and provides long-term, reliable performance, please read and follow this instruction manual carefully.

Manual language

- UK** This user manual is written in English. For other languages, please use an auto-translation service of your choice.
- FR** Ce guide est écrit en anglais. Pour les autres langues, veuillez utiliser un service de traduction automatique de votre choix.
- DE** Diese Anleitung ist in Englisch verfasst. Für andere Sprachen verwenden Sie bitte einen automatischen Übersetzungsdienst Ihrer Wahl.
- ES** Este manual está escrito en Inglés. Para otros idiomas, utilice un servicio de traducción automática de su elección.
- PT** Este manual está escrito em Inglês. Para outros idiomas, use um serviço de tradução automática de sua escolha.
- IT** Questo manuale è scritto in inglese. Per altre lingue, utilizza un servizio di traduzione automatica a tua scelta.

Important safety instructions

- Read these instructions and all markings on the product. Keep these instructions.
- Heed all warnings and instructions, both in this manual and on the product.
- Clean only with a dry cloth. Unplug the unit or its power adaptor/charger from AC supply before cleaning.
- Do not use this product near water and avoid any exposure to water.
- Before connecting this product to any AC supply (if any), make sure to check whether the AC mains voltage and frequency match the indication on the product and its packaging.
- Only connect this product or its power adaptor/charger to an AC supply (if any) with sufficient power handling, protective earth connection, ground-fault (earth-fault) protection and overload protection.
- Disconnect the product or its power adaptor/charger from the AC supply (if any) during thunderstorms or longer periods of being unused.

EC Declaration of Conformity

The manufacturer

Adelto Industries, Unit 4 Britannia Business Park, Comet Way,
Southend-on-Sea, Essex, SS2 6GE, United Kingdom

Declares at his sole responsibility that the equipment

INTUSONIC 2SDL160

is in conformity with the following directives/standards/regulations:

EMC Directive 2014/30/EU

EN55035:2017

LVD Directive 2014/35/EU

EN62368-1

ROHS2 Directive 2011/65/EU & 2015/863/EU

EN63000:2018

And is marked as follows:



Southend-on-Sea, 19th March 2021

Authorized Signature

Technical Data

Rated Power @ 4Ω/8Ω2x150W/80W
Frequency response20H-20kHz (+-0.5dB)
S/N ratio (8Ω, full power)> 89dB
Residual Noise (full power)< -71dBu
Crosstalk Damping> 63dB
THD&N (rated power)<0.12%
AC IN115/230V~, 50/60Hz, max 350W
Dimensions WxDxH482.6x245x44 mm
Weight3.3 kg

Warranty

This product is guaranteed to be free of defects in material and workmanship at the time of purchase. Send-in warranty repair is granted for a period determined by

- A period of at least 6 months (from the date of purchase), or the minimum period required by law in the territory of sale, whichever is longer.
- A period of no longer (from the date of purchase) than the specified average lifetime of a component by the component's manufacturer.

- Make sure any heat sink or other cooling surface, or any air convection slot, is exposed sufficiently to free air circulation and is not blocked.
- Do not operate this product in environmental temperatures exceeding 35 degrees Celsius and/or 85% relative humidity.
- Position the product in a safe and stable place for operation, out of reach of unauthorized persons.
- Make sure any cable connections to and from the product are neither subject to potentially destructive mechanical impact nor present any risk of stumbling or other accident risk to people.
- Audio equipment may generate sound pressure levels sufficient to cause permanent hearing damage to persons. Always start up at low volume settings and avoid prolonged exposure to sound pressure levels exceeding 90dB.
- Do not open this product for service purposes. There are no user-serviceable parts inside.
- Warranty will be void in any case of unauthorized service by the user or other not authorized persons.
- Take any precaution required by local law, applicable regulations or good business practice to avoid injury of people or material damage by use of this product.

Symbols used in this manual



DANGER! Safety hazard. Risk of injury or death.



ATTENTION! Read manual before installation and operation.



WARNING! Hazardous voltage. Risk of severe or fatal electric shock.



WARNING! Fire hazard.

Health Advice

This unit may produce and absorb electromagnetic radiation. The strength of radiation and the sensitivity for disturbing interference matches the CE and FCC requirements. A corresponding sign is printed on the backside of the unit. Any change or modification may affect the behavior of the unit concerning electromagnetic radiation, with the CE and FCC requirements eventually not to be met any more. The manufacturer takes no responsibility in this case.

Functional Advice (only for powered products)

This unit is immune to the presence of electromagnetic disturbances – both conducted and radiated - up to a certain level. Under peak conditions, the unit is classified to show a “class C” performance criteria and may encounter temporary degradation or loss of function which may need manual help to recover. In such case, switch the unit off and back on to recover.

Environmental Advice

This unit is built to conform to the ROHS-2 standard according to directive 2011/65/EU and the WEEE directive 2012/19/EU of the European Parliament and of the Council of the European Union. Under these regulations, the product shall not be discarded into regular garbage at the end of its life, but shall be returned to authorized recycling stations.

Battery Advice (only for battery-powered products)

- Some products may contain a battery. Refer to the further chapters of this manual to determine whether this product contains a battery, and whether this is removable and/or rechargeable.
- Where applicable, adhere to the relative regulations in aviation transport.
- If the battery is rechargeable, the battery might not be fully charged or partly discharged at the time of purchase. Recharge before use. Only use recommended or included chargers with appropriate voltage/current rating.



WARNING! Fire hazard. Batteries might heat up during charging. Only charge in a place with sufficient air convection.

Wireless Advice

- Some products may contain a wireless transmitter, receiver or transceiver. Refer to the further chapters of this manual to determine whether this product contains a wireless function, and in which frequency this operates.
- Make sure the frequency of operation does not require a specific license in the territory you operate the product in. If it does, obtain such license prior to any operation.
- Certain wireless technologies are designed for short distance operation. The actual distance will depend on how jammed the

Block diagram

Speaker Cabling

Aside of proper signal cabling for the input signals, the choice of suitable speaker cables is often a neglected but at the same time essential point of amplifier installation. Speaker cables, specifically long ones, can significantly contribute to the load impedance of the amplifier, thus reducing the power output and turning some of the output power into heat instead of delivering it to the speakers. The most important aspect is to keep cables as short as possible and to choose a sufficient copper cross-section, with maximum length values as per below.

Cross-Section	0.75mm ²	1.50mm ²	2.50mm ²	4.00mm ²
AWG	18	15	13	11
Ω per m	0.0224	0.0112	0.00672	0.00472
2Ω load	4.00m	8.00m	12.00m	16.00m
4Ω load	8.00m	16.00m	24.00m	32.00m
6Ω load	15.00m	30.00m	45.00m	60.00m
8Ω load	22.50m	45.00m	60.00m	90.00m

Note: 2 Ω loads are only listed for reference but not applicable to this product.

frequency band is at the location of use. In adverse cases, operational distances might be as low as 5m. In normal circumstances, 10m can be assumed. Test the operational distance prior to relying on the wireless functionality in a specific application.

Unpacking

Please check that the box contains the following items:

- 1 pc. main unit
- 1 pc. AC cord set
- 1 pc. instruction manual

If any part is missing, please contact your dealer immediately for replacement.

WARNING! After unpacking, and before plugging the AC cord in the wall outlet, check whether the AC mains voltage and frequency is the same as this product is specified for (see rear panel of product). Whenever the specified voltage or your AC plug should not match the local conditions, do NOT plug the AC cord into the wall outlet and contact your dealer immediately.

AC Mains Voltage Setting

If the AC mains voltage of your power outlet and the setting of the AC supply voltage on your unit do not match, contact your dealer, contractor or a qualified service workshop to change the setting of the AC voltage selector. The AC voltage selector switch is located on the side panel of the unit, close to the AC inlet.

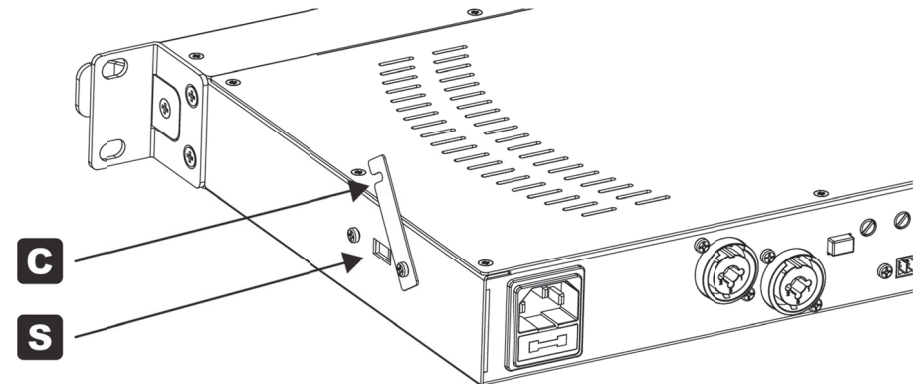

For a qualified technician to change the AC voltage setting, the AC cord shall be detached, the security cover (C) shall be flipped up, and the Voltage selector switch (S) shall be set to the new position. Afterwards, the security cover (C) shall be set back into a protective position to avoid tampering with the switch.

Rack/Cabinet Mounting

This product comes pre-assembled with 19" rack ears and handles. Depending on the location of installation and use, it might be commendable to remove either only the handles, or both the rack ears and handles. To do so, remove the screws at the side panel of the units as shown: To remove the handle (H), remove the single center screw out of the group of 3 screws at the front side of the metal cabinet. Pull the handles out to the front. To also remove the rack ears (E), remove the remaining two screws and then remove the rack ear.

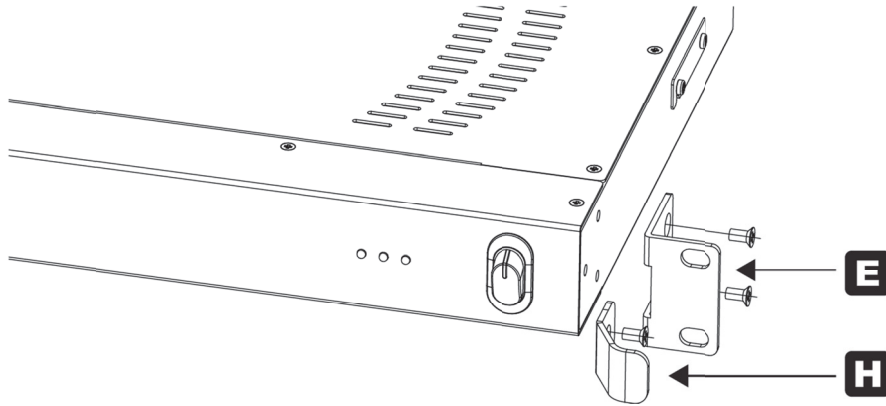

About this product

The 2SDL160 is a versatile low-impedance audio amplifier for installation purposes. It sports most of its controls on the rear panel to avoid any unnecessary user interaction. Input forwarding allow stereo and mono operation in a very simple manner, and the EQ, filter and level setting options per channel allow this unit to be configured for any size and complexity of sound systems. Silent, fan-less convection cooling enables low noise emissions and excellent reliability.

Signal Cabling

This product may use all or a selection of the below connector types, for which the pin assignment must comply with the following specification. Always make sure to use good connectors and cables to ensure proper operation. Balanced connections are to be preferred over unbalanced connections where applicable and feasible. Avoid unbalanced connections exceeding 2m of cable length.

	Structure	Balanced connection	Unbalanced connection
XLR male		red = 2 black = 3 shield = 1	red = 2 shield = 1+3
XLR female		red = 2 black = 3 shield = 1	red = 2 shield = 1+3
6.35mm TRS-stereo		red = tip black = ring shield = sleeve	red = tip shield = sleeve+ring
6.35mm TRS-mono		red = tip black = sleeve shield = uncon.	red = tip shield = sleeve
3.5mm TRS-stereo		red = tip black = ring shield = sleeve	red = tip shield = sleeve+ring
RCA		red = tip black = sleeve shield = uncon.	red = tip shield = sleeve
Terminal Plug		red = 1 black = 2 shield = 3	red = 1 shield = 2+3

CABLE Types

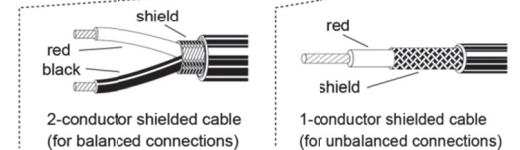

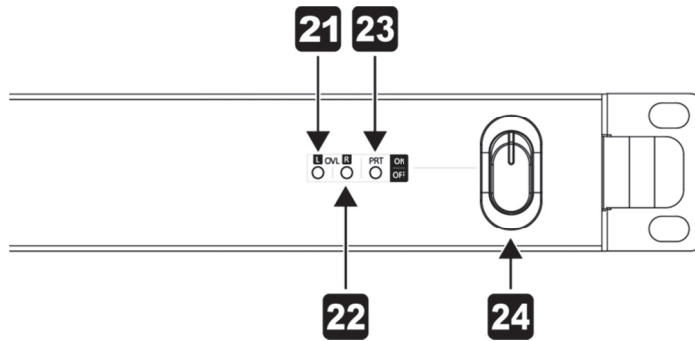

- 21 Left Overload Indicator.** This indicator signals the input signal exceeding the recommendable level, and shall only be occasionally flashing. In case this indicator is invoked frequently, reduce the input sensitivity setting via the rear controls (9) to avoid distortion.
- 22 Right Overload Indicator.** This indicator signals the input signal exceeding the recommendable level, and shall only be occasionally flashing. In case this indicator is invoked frequently, reduce the input sensitivity setting via the rear controls (9) to avoid distortion.
- 23 Protection Indicator.** This indicator signals the amplifier's protection circuitry being tripped. This might be caused by over-temperature, overcurrent, DC voltage or a short circuit at the output and may be accompanied with a temporary shutdown of the amplifier until safe operating conditions are restored. If this indicator does not turn off, the unit may need servicing.
- 24 Power switch.** Switches the unit on and off. Make sure to switch the unit off when not in use. The ON position is indicated by a backlight.

Controls and Connections

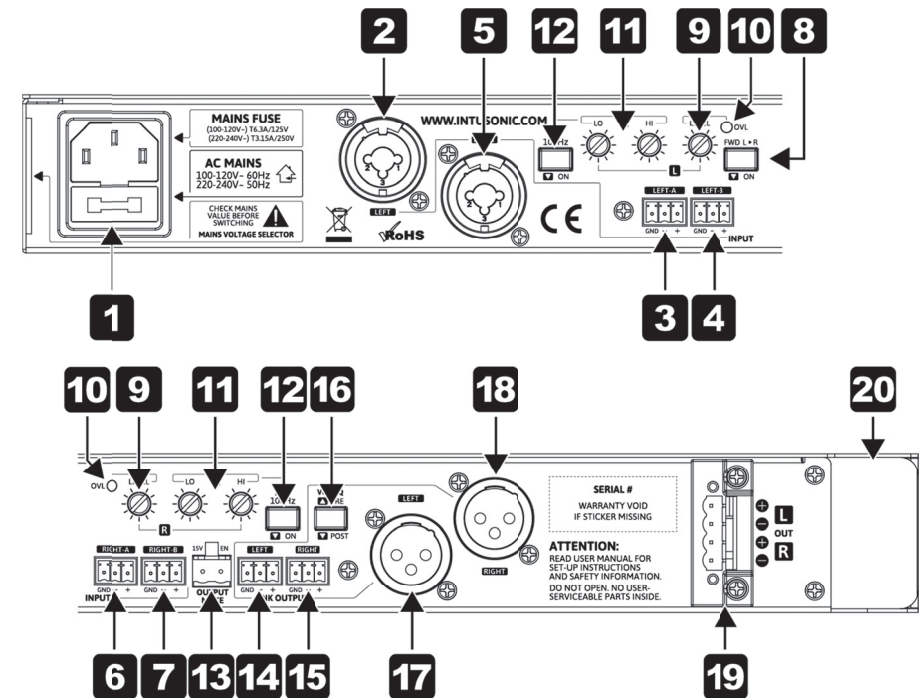

- 1 AC inlet and fuse holder.** Use the supplied AC cord to connect the unit to AC mains. Make sure voltage and frequency stated and set on the unit comply with your local AC supply. The fuse can be accessed by the small drawer at the AC inlet. To change the fuse, unplug the AC cord first, pull out the fuse drawer and replace the fuse ONLY with a fuse of SAME voltage and rating. If the fuse blows again after replacement, hand over the unit to qualified service personnel.
- 2 Left Input.** This is a balanced TRS+XLR Combo connector which accepts line level input signals. This connector is in parallel with the Dual terminal strip inputs (3) (4).
- 3 Left Input (A).** This is a balanced 3.5mm terminal strip input which accepts line level input signals. This input is summed with the Left Input B (4). This way, stereo sources can be summed to mono for amplification. The mono sum is in parallel with the Combo input (2).

- 4 Left Input (B).** This is a balanced 3.5mm terminal strip input which accepts line level input signals. This input is summed with the Left Input A (3). This way, stereo sources can be summed to mono for amplification. The mono sum is in parallel with the Combo input (2).
- 5 Right Input.** This is a balanced TRS+XLR Combo connector which accepts line level input signals. This connector is in parallel with the Dual terminal strip inputs (6) (7).
- 6 Right Input (A).** This is a balanced 3.5mm terminal strip input which accepts line level input signals. This input is summed with the Right Input B (7). This way, stereo sources can be summed to mono for amplification. The mono sum is in parallel with the Combo input (5).
- 7 Right Input (B).** This is a balanced 3.5mm terminal strip input which accepts line level input signals. This input is summed with the Right Input A (6). This way, stereo sources can be summed to mono for amplification. The mono sum is in parallel with the Combo input (5).
- 8 Forward L to R switch.** This switch allows the signal at the input L (3) to be internally forwarded to input R (5) without any further external cabling. Once this switch is pressed, any signals connected to the input R (5 / 6 / 7) will be ignored. All other controls (9 / 10 / 11 / 12) remain to operate independently.
- 9 Channel level control.** This control allows to set the input sensitivity levels of the channels L and R independently. Make sure that even at peak input signal conditions, this control is set to avoid the OVL indicator (10) to be lit more than occasionally. Adjustments shall be made with a small screw driver. Note that the total angle is 300 degrees; do not apply excessive force with the screw driver.
- 10 Input overload indicator.** This LED will light up at +4dBu, and helps to find a maximum allowed setting for the channel level controls (9). Make sure that this indicator is only occasionally lit even under peak input signal conditions.
- 11 Channel Equalizer.** The two rotary controls allow to change the tonal setting of the channel output to match local requirements, connected speaker systems and/or the user's taste. Be aware that any boost settings for low or high frequencies apply additional stress to the connected speakers and shall be applied with care. Adjustments shall be made with a small screw driver. Note that the total angle is 300 degrees; do not apply excessive force with the screw driver.
- 12 High Pass Filter Switch.** Pressing this switch will engage an 18dB/Oct. HPF at 100Hz. This is recommendable when the respective amplifier channel feeds a smaller speaker which is incapable of reproducing very low frequencies. Engaging this switch will protect the speaker from harmful low-frequency input energy. Do

- NOT engage this switch and boost the LowEQ (11) as these controls counteract.
- 13 Music Mute input.** This is a terminal block input which allows to remotely mute the output (19) by simply shortening the contacts.
- 14 Left Link Output.** This is a balanced 3.5mm terminal strip output which carries the same signal as the left input (2 / 3 / 4). Depending on the setting of the Link Routing switch (16) the signal at this link output is either taken straight from the input (2 / 3 / 4) or only after being processed by the left channel's level and equalizer controls (9 / 11). This connector is in parallel with the left link output XLR connector (17).
- 15 Right Link Output.** This is a balanced 3.5mm terminal strip output which carries the same signal as the right input (5 / 6 / 7). Depending on the setting of the Link Routing switch (16) the signal at this link output is either taken straight from the input (5 / 6 / 7) or only after being processed by the left channel's level and equalizer controls (9 / 11). This connector is in parallel with the right link output XLR connector (17).
- 16 Link Output Routing Switch.** When this switch is un-pressed, the Link outputs (14/15/17/18) carry the unaltered input signal from the left and right inputs (2/3/4/5/6/7). This will allow a further amplifier to use the same signals, but with its own level and EQ settings. When this switch engaged, the link output routing will be changed to a point after the level and EQ settings. This will allow a further amplifier to follow the level and EQ settings of the prior amplifier in the chain.
- 17 Left Link Output.** This balanced male XLR socket replicates the signal at the terminal strip output (14).
- 18 Right Link Output.** This balanced male XLR socket replicates the signal at the terminal strip output (15).
- 19 Speaker Output.** This is a 4-pole 5mm pitch terminal strip connector. Connect the speakers here. Note:
- ▶ Minimum total load impedance is 4 Ohms.
 - ▶ This amplifier has no bridge output provision. Do not attempt any cross-connection between the output channels.
- 20 Heatsink.** For silent and maintenance-free operation, this amplifier is convection cooled. This requires the heatsink to have access to vertical airflow. Do not block the heatsink by mounting into narrow compartments or by locating other items at all sides of the amplifier. Note that the heatsink can reach touch temperatures of up to 60 degrees C. Do not locate flammable materials close to the heatsink.