

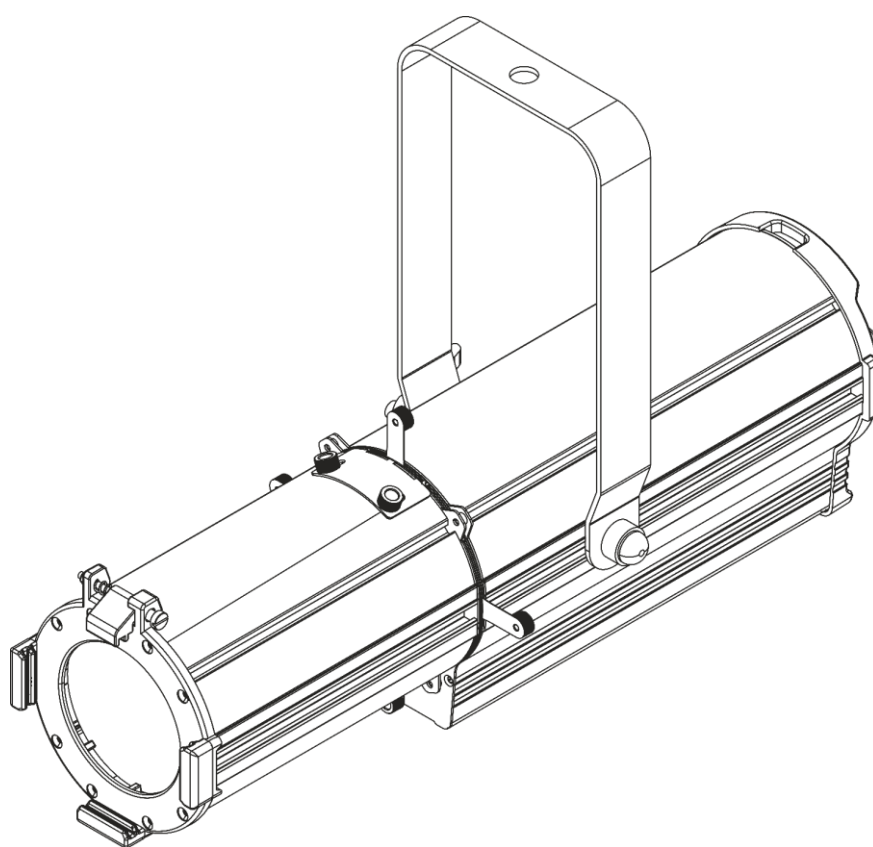

USER MANUAL



ENGLISH

ACT Profile 50 RGBAL

V1

Product code: 34033

Preface

Thank you for purchasing this Showtec product.

The purpose of this user manual is to provide instructions for the correct and safe use of this product.

Keep the user manual for future reference as it is an integral part of the product. The user manual shall be stored at an easily accessible location.

This user manual contains information concerning:

- Safety instructions
- Installation and operation of the device
- Intended and non-intended use of the device
- Maintenance procedures
- Troubleshooting
- Transport, storage and disposal of the device

Non-observance of the instructions in this user manual may result in serious injuries and damage of property.

©2023 Showtec. All rights reserved.

No part of this document may be copied, published or otherwise reproduced without the prior written consent of Highlite International.

Design and product specifications are subject to change without prior notice.

For the latest version of this document or other language versions, please visit our website www.highlite.com or contact us at service@highlite.com.

Highlite International and its authorized service providers are not liable for any injury, damage, direct or indirect loss, consequential or economic loss or any other loss arising from the use of, or inability to use or reliance on the information contained in this document.

Table of contents

1. Introduction	4
1.1. Before Using the Product	4
1.2. Intended Use	4
1.3. Product Lifespan	4
1.4. LEDs Lifespan	4
1.5. Text Conventions	4
1.6. Symbols and Signal Words	5
1.7. Symbols on the Information Label	5
2. Safety	6
2.1. Warnings and Safety Instructions	6
2.2. Requirements for the User	8
3. Description of the Device	9
3.1. Front View	9
3.2. Back View	10
3.3. Included Accessories	11
3.4. Optional Accessories	11
3.5. Product Specifications	12
3.6. Dimensions	13
4. Installation	14
4.1. Safety Instructions for Installation	14
4.2. Installation Site Requirements	14
4.3. Rigging	14
4.4. Angle Adjustment	15
4.5. Beam Angle Adjustment	15
4.6. Color Frame Installation	16
4.7. Beam Shaping	16
4.8. Gobo Replacement	17
4.9. Changing the Gobo	18
4.10. Connecting to Power Supply	19
4.11. Power Linking of Multiple Devices	19
5. Setup	20
5.1. Warnings and Precautions	20
5.2. Stand-alone Setup	20
5.3. DMX Connection	20
5.3.1. DMX-512 Protocol	20
5.3.2. DMX Cables	20
5.3.3. DMX Linking	21
5.3.4. DMX Addressing	22
6. Operation	23
6.1. Safety Instructions for Operation	23
6.2. Control Modes	23
6.3. Control panel	24
6.4. Start-up	24
6.5. Menu Overview	25
6.6. Main Menu Options	27
6.6.1. DMX Functions	27
6.6.1.1. DMX Address	27
6.6.1.2. DMX Channel Mode	28
6.6.1.3. DMX Fail	28
6.6.1.4. View DMX Value	28
6.6.2. Show Settings	29
6.6.2.1. Function Mode	29
6.6.2.2. Show Chase	29

6.6.2.3.	Show Speed	29
6.6.3.	Static Color	30
6.6.4.	Fixture Settings.....	30
6.6.5.	Display Settings	31
6.6.6.	Fixture Test	31
6.6.6.1.	Manual Defined.....	31
6.6.7.	Fixture Information	32
6.6.8.	Special Functions.....	32
6.7.	Manual Operation	32
6.8.	DMX Channels	33
6.8.1.	5 Channels, 8 Channels, 12 Channels	33
6.9.	RDM Information.....	35
6.9.1.	RDM Details.....	35
6.9.2.	Supported RDM PIDs (Parameter IDs)	35
7.	Troubleshooting	36
8.	Maintenance	37
8.1.	Safety Instructions for Maintenance.....	37
8.2.	Preventive Maintenance	37
8.2.1.	Basic Cleaning Instructions	37
8.3.	Corrective Maintenance	38
8.3.1.	Replacing the Fuse	38
9.	Deinstallation, Transportation and Storage	39
9.1.	Instructions for Transportation	39
9.2.	Instructions for Deinstallation.....	39
9.3.	Storage	39
10.	Disposal	39
11.	Approval.....	39

1. Introduction

1.1. Before Using the Product



Important
Read and follow the instructions in this user manual before installing, operating or servicing this product.

The manufacturer will not accept liability for any resulting damages caused by the non-observance of this manual.

After unpacking, check the contents of the box. If any parts are missing or damaged, contact your Highlite International dealer.

Your shipment includes:

- Showtec ACT Profile 50 RGBAL
- Color frame
- Schuko to Power Pro cable (1,5 m)
- User manual

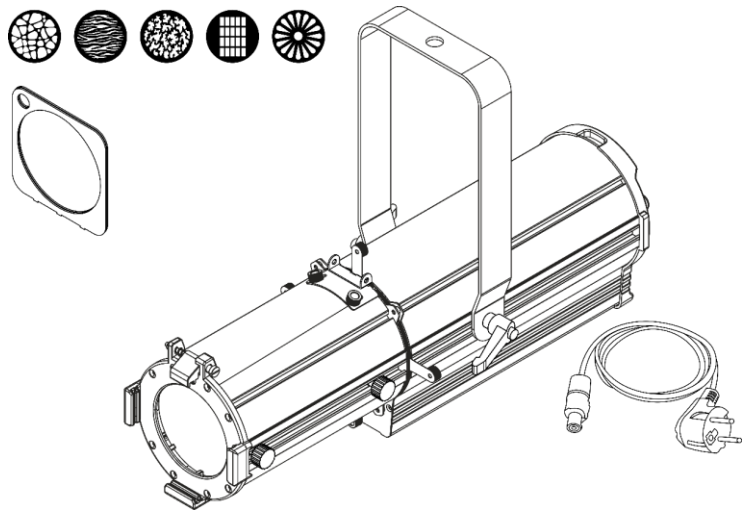

Fig. 01

1.2. Intended Use

This device is intended for use as a professional theater spotlight and is suitable for indoor installation only. It is not suitable for households or general lighting.

Any other use, not mentioned under intended use, is regarded as non-intended and incorrect use.

1.3. Product Lifespan

This device is not designed for permanent operation. Disconnect the device from the electrical power supply when it is not in use. This will reduce wear and improve the device's lifespan.

1.4. LEDs Lifespan

The light output of LEDs gradually decrease over time (lumen depreciation). High operating temperatures contribute to this process. The lifespan of LEDs can be extended by ensuring adequate ventilation and operating the LEDs at the lowest possible brightness.

1.5. Text Conventions

Throughout the user manual the following text conventions are used:







- Buttons: All buttons are in bold lettering, for example "Press the **UP/DOWN** buttons"
- References: References to chapters and parts of the device are in bold lettering, for example: "Refer to **2. Safety**", "turn the **adjustment handle (11)**"
- 0–255: Defines a range of values

- Notes: **Note:** (in bold lettering) is followed by useful information or tips

1.6. Symbols and Signal Words

Safety notes and warnings are indicated throughout the user manual by safety signs.



Always follow the instructions provided in this user manual.

	DANGER	Indicates an imminently hazardous situation which, if not avoided, will result in serious injury or death.
	WARNING	Indicates an imminently hazardous situation which, if not avoided, could result in serious injury or death.
	CAUTION	Indicates a potentially hazardous situation, which, if not avoided, may result in minor or moderate injury.
	Attention	Indicates important information for the correct operation and use of the product.
	Important	Read and observe the instructions in this document.
		Provides important information about the disposal of this product.

1.7. Symbols on the Information Label

This product is provided with an information label. The information label is located on the mounting bracket of the device.

The information label contains the following symbols:

	This device is designed for indoor use.
	This device falls under IEC protection class I.
	This device shall not be treated as household waste.

2. Safety



Important
Read and follow the instructions in this user manual before installing, operating or servicing this product.

The manufacturer will not accept liability for any resulting damages caused by the non-observance of this manual.

2.1. Warnings and Safety Instructions



DANGER
Danger for children

For adult use only. The device must be installed beyond the reach of children.

- Do not leave various parts of the packaging (plastic bags, polystyrene foam, nails, etc.) within children's reach. Packaging material is a potential source of danger for children.



DANGER
Electric shock caused by dangerous voltage inside

There are areas within the device where dangerous touch voltage (> 120 V DC) may be present.

- Do not open the device or remove any covers.
- Do not operate the device if the covers or the housing are open. Before operation, check if the housing is firmly closed and all screws are tightly fastened.
- Disconnect the device from electrical power supply before service and maintenance, and when the device is not in use.



DANGER
Electric shock caused by short-circuit

This device falls under IEC protection Class I.

- Make sure that the device is electrically connected to ground (earth). Connect the device only to a socket-outlet with ground (earth) connection.
- Do not cover the ground (earth) connection.
- Do not bypass the thermostatic switch or fuses.
- For replacement use fuses of the same type and rating only.
- Do not let the power cable come into contact with other cables. Handle the power cable and all connections with the mains with caution.
- Do not modify, bend, mechanically strain, put pressure on, pull or heat up the power cable.
- Make sure that the power cable is not crimped or damaged. Examine the power cable periodically for any defects.
- Do not immerse the device in water or other liquids. Do not install the device in a location where flooding may occur.
- Do not use the device during thunderstorms. Disconnect the device from the electrical power supply immediately.

**WARNING**
Risk of epileptic shock

Strobe lighting can trigger seizures in photosensitive epilepsy. Sensitive persons should avoid looking at strobe lights.

**Attention**
Power supply

- Before connecting the device to the power supply, make sure that the current, voltage and frequency match the input voltage, current and frequency specified on the information label on the device.
- Make sure that the cross-sectional area of the extension cords and power cables is sufficient for the required power consumption of the device.

**Attention**
General safety

- Do not connect this device to a dimmer pack.
- Do not switch the device on and off in short intervals. This reduces the device's life.
- Do not shake the device. Avoid brute force when installing or operating the device.
- Change the lens or the LEDs if they are visibly damaged to such an extent that their effectiveness is impaired, for example by cracks or deep scratches. Contact your Highlite International dealer for more information, as servicing can be performed only by instructed or skilled persons.
- If the device is dropped or struck, disconnect the device from the electrical power supply immediately.
- If the device fails to work properly, discontinue the use immediately.

**Attention**
For professional use only
This device shall be used only for the purposes it is designed for.

This device is designed to be used as a professional theater spotlight. Any incorrect use may lead to hazardous situations and result in injuries and material damage.

- This device is not suitable for households and for general lighting.
- This device is not designed for permanent operation.
- This device does not contain user-serviceable parts. Unauthorized modifications to the device will render the warranty void. Such modifications may result in injuries and material damage.



Attention

Before each use, examine the device visually for any defects.

Make sure that:

- All screws used for installing the device or parts of the device are tightly fastened and are not corroded.
- The safety devices are not damaged.
- There are no deformations on housings, fixations and installation points.
- The lens is not cracked or damaged.
- The power cables are not damaged and do not show any material fatigue.



Attention

Do not expose the device to conditions that exceed the rated IP class conditions.

This device is IP20 rated. IP (Ingress Protection) 20 class provides protection against solid objects greater than 12 mm, such as fingers, and no protection against harmful ingress of water.

2.2. Requirements for the User

This product may be used by ordinary persons. Installation, service and maintenance shall be carried out only by instructed or skilled persons. Contact your Highlite International dealer for more information.

Instructed persons have been instructed and trained by a skilled person, or are supervised by a skilled person, for specific tasks and work activities associated with the service of this product, so that they can identify risks and take precautions to avoid them.

Skilled persons have training or experience, which enables them to recognize risks and to avoid hazards associated with the installation, service and maintenance of this product.

Ordinary persons are all persons other than instructed persons and skilled persons. Ordinary persons include not only users of the product but also any other persons that may have access to the device or who may be in the vicinity of the device.

3. Description of the Device

The Showtec ACT Profile 50 RGBAL is a 50 watt RGBAL COB LED ellipsoidal with high CRI, It operates within a 14° - 32° manually adjustable zoom range and projects a hard-edge, precisely focused light. The ACT Profile 50 RGBAL features a manually and DMX controllable 0 - 100 % dimmer function and comes with 5 design gobos and a four-blade shutter system, allowing you to add the proper intensity of light where it's needed.

3.1. Front View

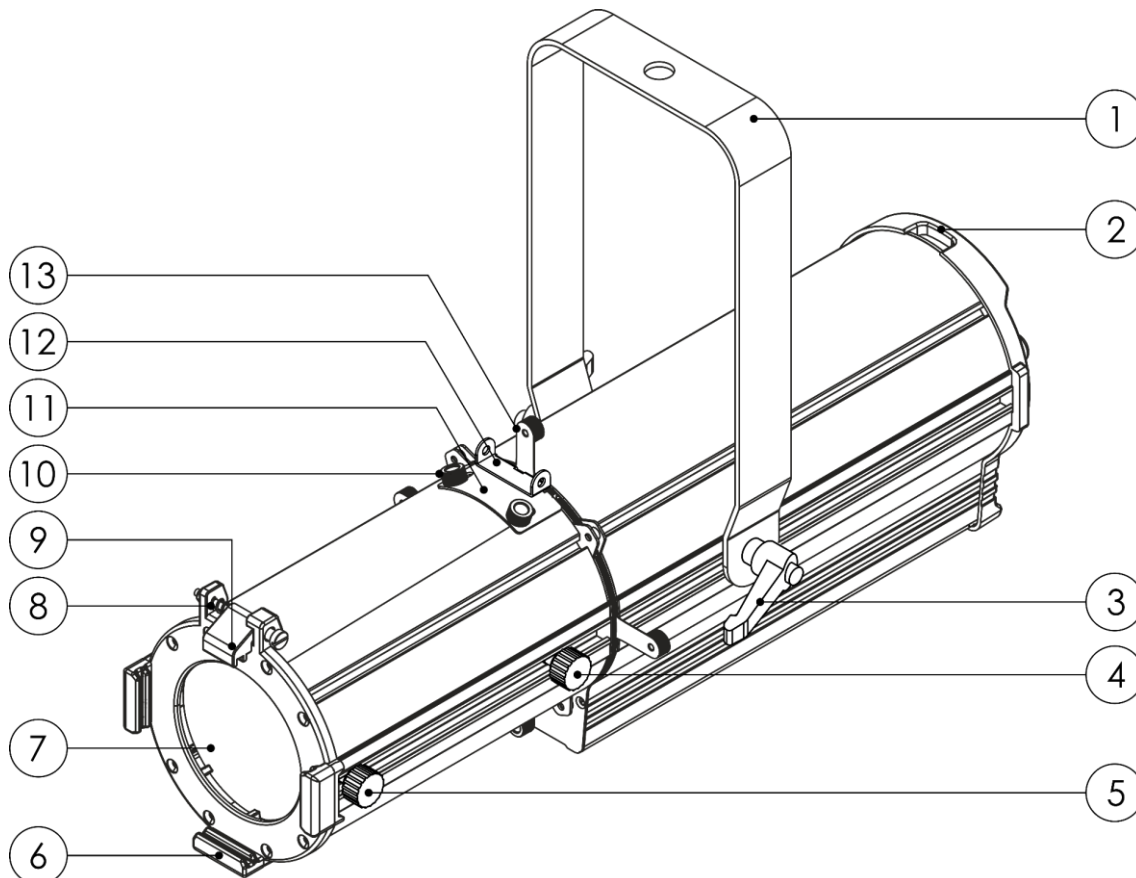

Fig. 02

- 01) Mounting bracket
- 02) Safety eye
- 03) Adjustment handle
- 04) Focus control
- 05) Zoom control
- 06) 3 x Color frame holders
- 07) Lens, 1 x 150 W 5-in-1 RGBAL LED
- 08) Spring-loaded screw
- 09) Color frame clip
- 10) 2 x Cover plate thumbscrews
- 11) Gobo slot cover plate
- 12) Gobo holder
- 13) 4 x Framing shutters

3.2. Back View

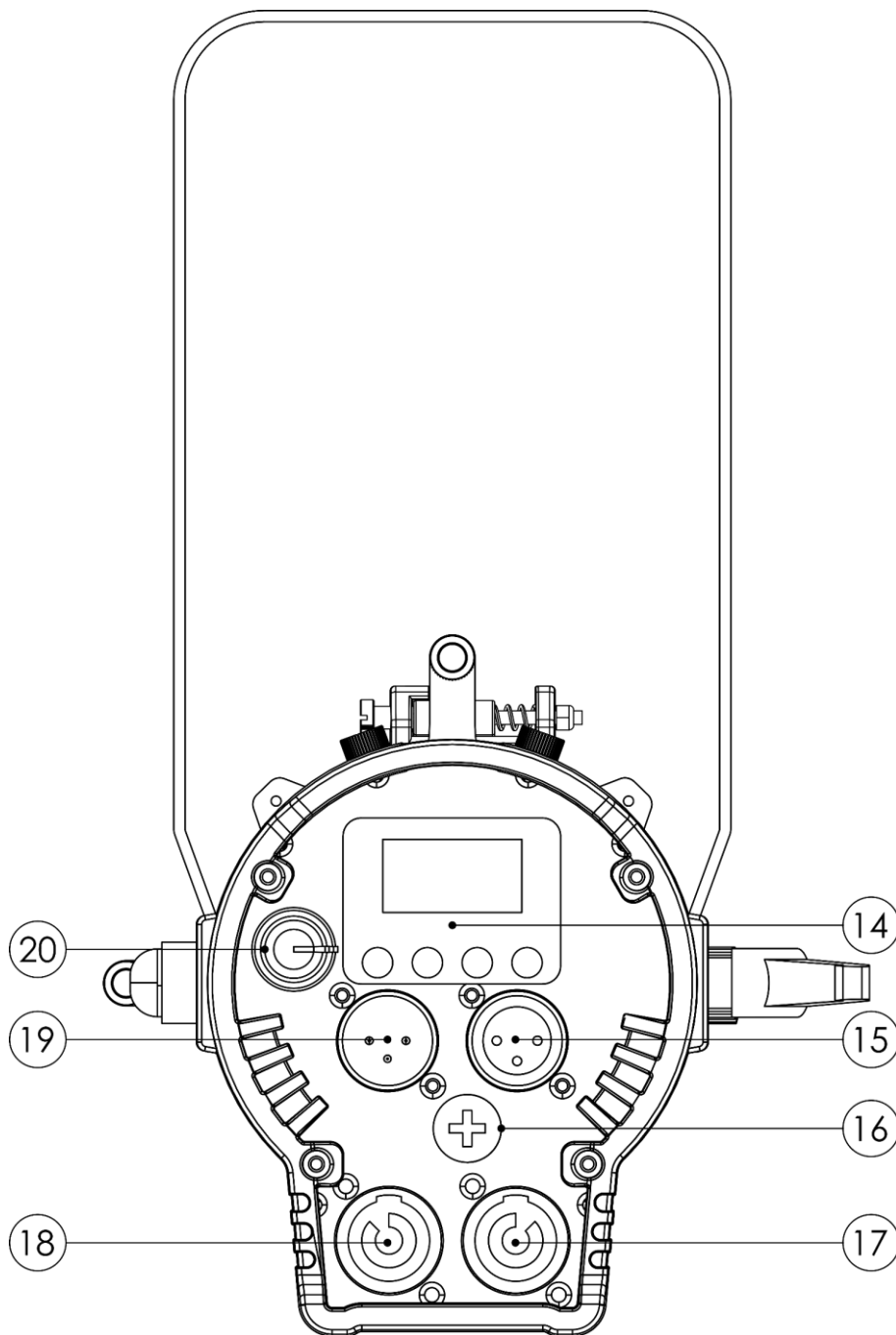

Fig. 03

- 14) Control panel: OLED display and control buttons
- 15) 3-pin DMX signal connector OUT
- 16) Fuse T 1 AL/250 V
- 17) Power Pro connector OUT 100–240 V, 50/60 Hz (Gray)
- 18) Power-pro connector IN 100–240 V, 50/60 Hz (Blue)
- 19) 3-pin DMX signal connector IN
- 20) Manual dimmer / Preset Color control

3.3. Included Accessories

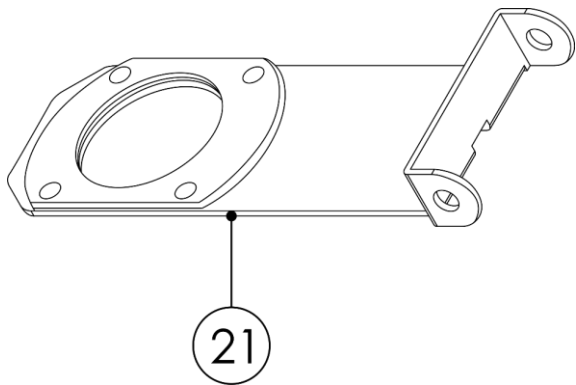

Fig. 04

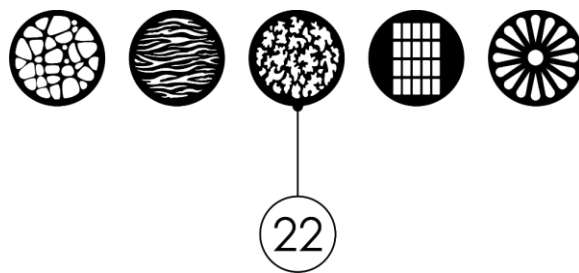

Fig. 05

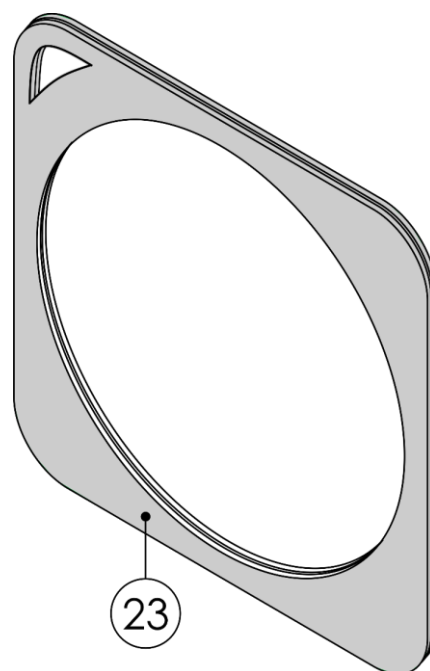

Fig. 06

- 21) Gobo holder
- 22) 5 x Included gobo set. See **4.8. Gobo Replacement** on page 17 and **4.9. Changing the Gobo** on page 18 for more information
- 23) Color frame

3.4. Optional Accessories



Fig. 07

An additional set of 5 metal gobos with seasonal patterns is available for purchase from Highlite International: [34050](#) – Season Gobo Set for Act Profile 50 (5 pieces)

3.5. Product Specifications

Model:	ACT Profile 50 RGBAL	
Electrical:		
Input voltage:	100–240 V AC, 50/60 Hz	
Power consumption:	55 W	
Fuse:	T 1 AL/250 V	
Physical:		
Dimensions:	430 x 169 x 293 mm (L x W x H) (without accessories)	
Weight:	3 kg (without accessories)	
Optics:		
Light source:	1 x 150 W RGBAL LED	
Dimmer:	0–100 %	
Strobe:	0–20 Hz	
Beam angle (circular)	13°–26°	
Zoom Ratio:	1:2	
Zoom:	14°–32° (manual adjustment)	
Total luminous flux:	220 lm	
Red:	195 lm	
Green:	271 lm	
Blue:	113 lm	
Amber:	107 lm	
Lime:	234 lm	
Illuminance @2m:	1205 lx	
Illuminance @3m:	536 lx	
Illuminance @5m:	193 lx	
CRI:	92	
CCT:	2800–10000 K	
Refresh rate:	1200 Hz	
Operation and control:		
Control:	Stand-alone (manual), DMX-512, RDM	
DMX channels:	5, 8 and 12-channel mode	
Control panel:	OLED display and buttons	
Manual operation:	Zoom	
Noise level:	31,9 dB	
Connections:		
Power connections:	Power Pro connectors IN/OUT (Blue/Grey)	
Data connections:	3-pin DMX connectors IN/OUT	
Signal pinouts:	Pin 1 (ground), pin 2 (-), pin 3 (+)	
Construction:		
Housing:	Aluminum	
Color:	Black	
IP rating:	IP20	
Cooling:	Convection/Axial fan	
Thermal:		
Maximum ambient temperature t_a :	45 °C	
Minimum ambient temperature t_a :	0 °C	
Minimum distance:		
Minimum distance from flammable surfaces:	0,5 m	

3.6. Dimensions

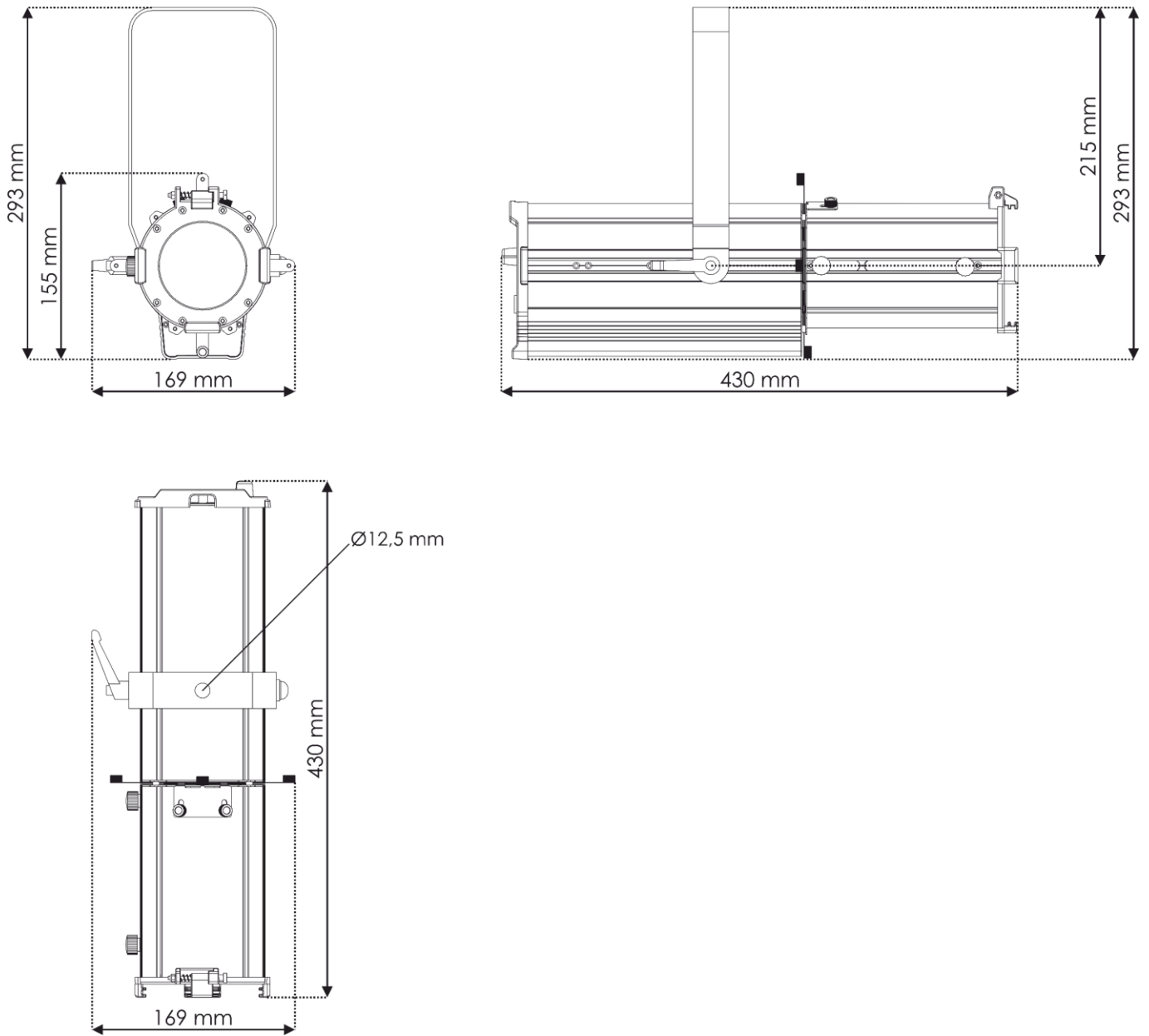

Fig. 08

4. Installation

4.1. Safety Instructions for Installation



WARNING

Incorrect installation can cause serious injuries and damage of property.

If trussing systems are used, installation must be carried out only by instructed or skilled persons.

Follow all applicable European, national and local safety regulations concerning rigging and trussing.

4.2. Installation Site Requirements

- The device can be used indoors only.
- The device can be mounted to a truss or another rigging structure in any orientation.
- The minimum distance to other objects must be bigger than 0,5 m.
- The maximum ambient temperature $t_a = 45\text{ °C}$ must never be exceeded.
- The relative humidity must not exceed 50 % with an ambient temperature of 45 °C.

4.3. Rigging

The device can be mounted to a truss or other rigging structure in any orientation. Make sure that all loads are within the pre-determined limits of the supporting structure.



CAUTION

Restrict the access under the work area during rigging and/or derigging.

To mount the device, follow the steps below:

- 01) Use a clamp to attach the device to the supporting structure, as shown in Fig. 09. Make sure that the device cannot move freely.
- 02) Secure the device with a secondary suspension, for example a safety cable. Make sure that the secondary suspension can hold 10 times the weight of the device. If possible, the secondary suspension should be attached to a supporting structure independent of the primary suspension. Put the safety cable through the **safety eye (02)**, as shown in Fig. 09.

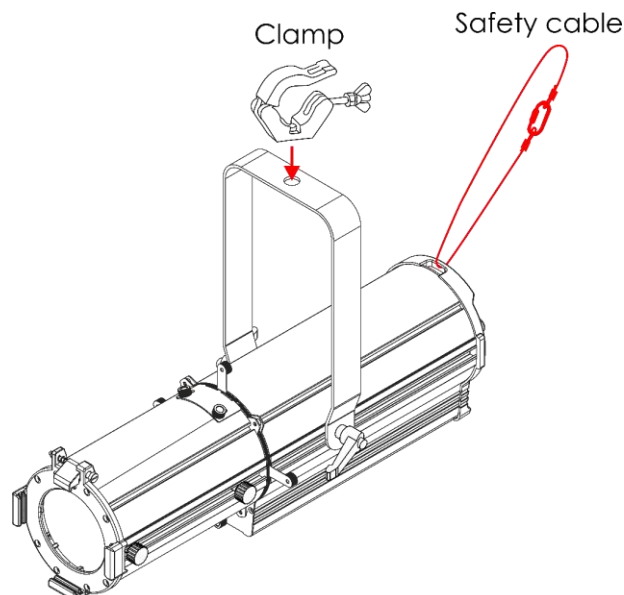

Fig. 09

4.4. Angle Adjustment

You can adjust the angle of the device with the **adjustment handle (03)**.

- 01) Turn the **adjustment handle (03)** counterclockwise to loosen it.
- 02) Tilt the device to the desired angle (see Fig. 10).
- 03) Turn the **adjustment handle (03)** clockwise to tighten it.

Note:

Make sure that the device cannot move freely after the **adjustment handle (03)** is tightened.

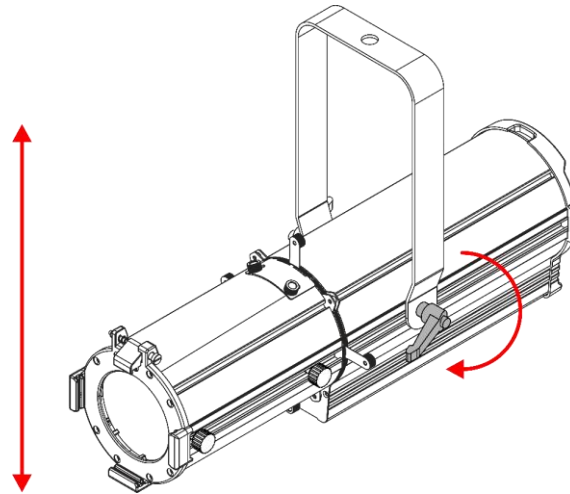

Fig. 10

4.5. Beam Angle Adjustment

The beam angle of the ACT Profile 50 RGBAL can be adjusted manually in the range 14°–32°. To adjust the beam angle, follow the steps below:

- 01) Turn the **focus control (04)** and the **zoom control (05)** counterclockwise to loosen them.
- 02) Slide the controls forwards or backwards to achieve the desired beam angle (see Fig. 11).
- 03) Once the fixture is focused, turn the **focus control (04)** and the **zoom control (05)** clockwise to tighten them. Do not overtighten them.

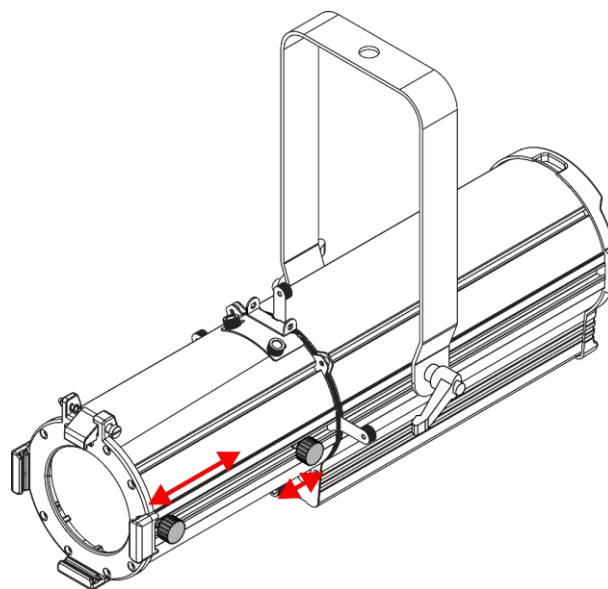

Fig. 11

4.6. Color Frame Installation

The ACT Profile 50 RGBAL is delivered with a color frame. You can insert a color gel or a diffusion filter into the color frame. To install the color frame, follow the steps below:

- 01) Push the **spring-loaded screw (08)** and at the same time lift the **color frame clip (09)** and flip it backwards (see Fig. 12).
- 02) Insert a color gel or a diffusion filter into the **color frame (23)**.
- 03) Insert the **color frame (23)** into the **color frame holders (06)** (see Fig. 13).
- 04) Pull the **color frame clip (09)** downwards to release the **spring-loaded screw (08)** (see Fig. 14). The color frame will be locked in position.
- 05) Secure the color frame to the overhead structure with an appropriate secondary attachment, for example a safety cable. Put the safety cable through the safety eye of the color frame.

Note:

Make sure that the color frame is locked in position with the color frame clip before using the device.

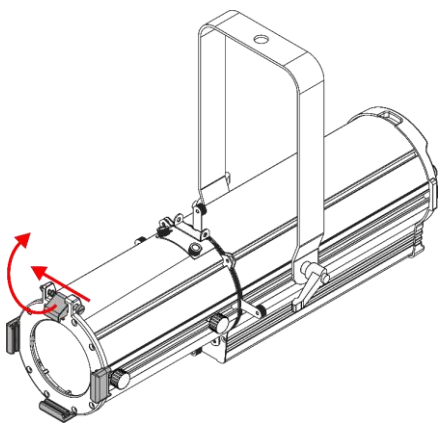

Fig. 12

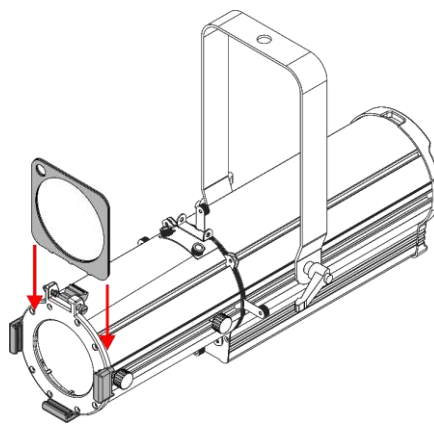

Fig. 13

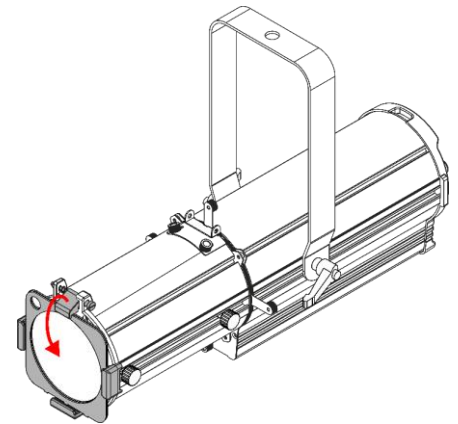

Fig. 14

4.7. Beam Shaping

You can shape the beam with the 4 **framing shutters (03)**. Move the **framing shutters (03)** back and forth to modify the shape of the beam (see Fig. 15).

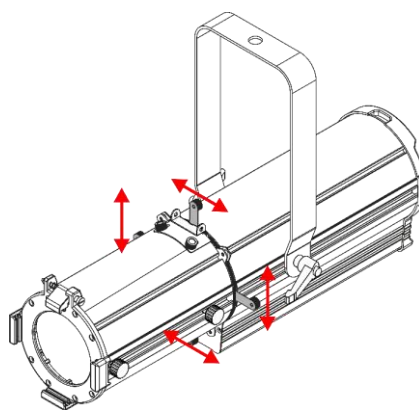

Fig. 15

4.8. Gobo Replacement

The ACT Profile 50 RGBAL is delivered with a gobo holder and a set of 5 metal gobos. You can order an additional gobo set of 5 metal gobos with seasonal patterns (order code 34050). To replace the gobo, follow the steps below:

- 01) Loosen the two **cover plate thumbscrews (10)** (see Fig. 16). **Do not remove the thumbscrews.**
- 02) Slide the **gobo slot cover plate (10)** towards the **lens (07)** (see Fig. 17).
- 03) Take the **gobo holder (12)** out of the of gobo slot (see Fig. 18).

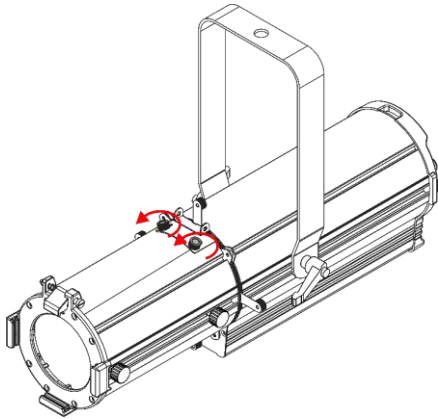

Fig. 16

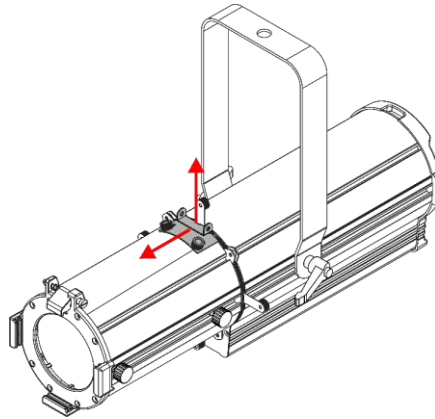

Fig. 17

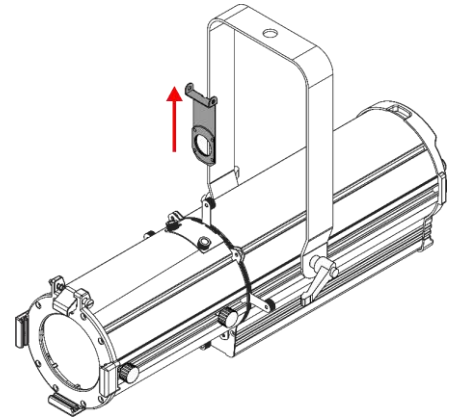

Fig. 18

- 04) Change the gobo in the **gobo holder (12)**. See **Changing the Gobo** on page 18 for more information.
- 05) Insert the **gobo holder (12)** back into the gobo slot (see Fig. 19).
- 06) Slide the **gobo slot cover plate (11)** towards the **gobo holder (12)** (see Fig. 20).
- 07) Tighten the two **cover plate thumbscrews (10)** to secure the **gobo slot cover plate (11)** at its place (see Fig. 21).

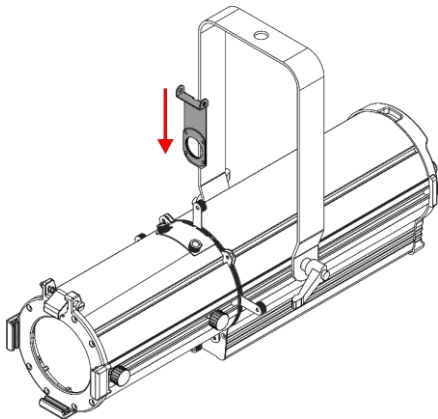

Fig. 19

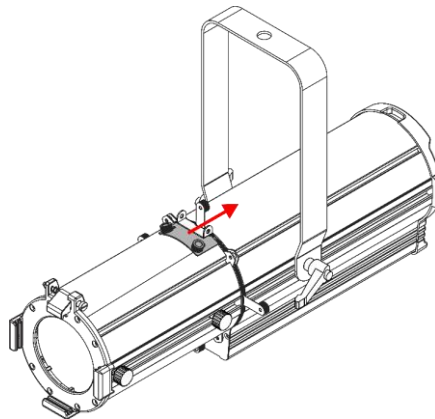

Fig. 20

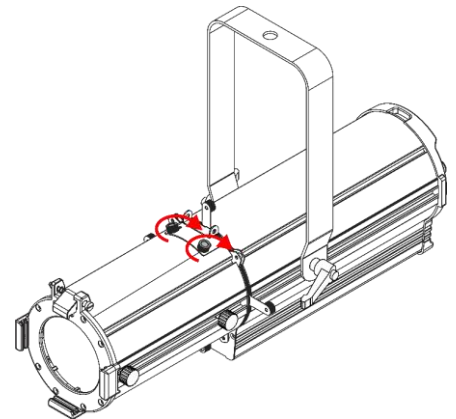

Fig. 21

4.9. Changing the Gobo

The ACT Profile 50 RGBAL is delivered with a gobo holder and a set of 5 metal gobos. To replace the gobo, follow the steps below:

- 01) Remove the retaining ring from the **gobo holder (12)** with needle-nose pliers or a similar sharp tool.
- 02) Change the metal gobo. Make sure that the painted (black) side of the gobo is facing upwards as shown on Fig. 22. When inserted back into the gobo slot, the painted (black) side should be facing the **lens (07)**.

Note:

Make sure that painted (black) side of the gobo is facing the lens.

- 03) Replace the retaining ring and secure it into position.

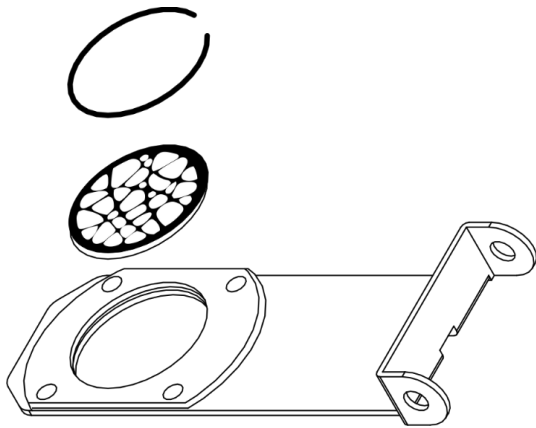

Fig. 22

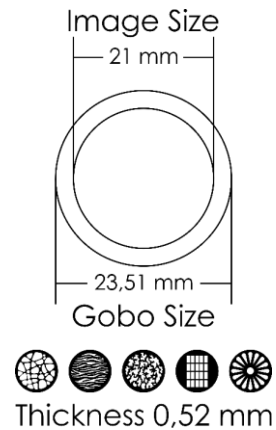

Fig. 23

4.10. Connecting to Power Supply



DANGER
Electric shock caused by short-circuit

The device can be powered by 100–240 V 50/60 Hz AC mains power. Do not supply mains power at any other voltage or frequency to the device.

This device falls under IEC protection class I. Make sure that the device is always electrically connected to the ground (earth).

Before connecting the device to the socket-outlet:

- Make sure that the power supply matches the input voltage specified on the information label on the device.
- Make sure that the socket-outlet has ground (earth) connection.

Connect the device to the socket outlet with the power plug. Do not connect the device to a dimmer circuit, as this may damage the device.

4.11. Power Linking of Multiple Devices

This device supports power linking. Power can be relayed to another device via the power OUT connector. Note that the input and the output connectors have different designs: one type cannot be connected to the other.

Power linking of multiple devices must be carried out only by instructed or skilled persons.



WARNING
Incorrect power linking may lead to overload of the electrical circuit and result in serious injuries and damage of property.

To prevent overload of the electrical circuit, when power linking multiple devices:

- Use cables with sufficient current-carrying capacity. The power cable supplied with the device is not suitable for power linking of multiple devices.
- Make sure that the total current draw of the device and all connected devices does not exceed the rated capacity of the power cables and the circuit breaker.
- Do not link more devices on one power link than the maximum recommended number.

Maximum recommended number of devices:

- at 100–120 V: 15 devices ACT Profile 50 RGBAL
- at 200–240 V: 30 devices ACT Profile 50 RGBAL

5. Setup

5.1. Warnings and Precautions



Attention

Connect all data cables before supplying power.

Disconnect power supply before connecting or disconnecting data cables.

5.2. Stand-alone Setup

When the ACT Profile 50 RGBAL is not connected to a controller or to other devices, it functions as a stand-alone device. It can be operated manually via the control panel and the manual controls or via an optional remote control.

For more information about the control modes, refer to **6.2. Control Modes** on page 23.

5.3. DMX Connection

5.3.1. DMX-512 Protocol

You need a DMX serial data link to run light shows of one or more devices using a DMX-512 controller.

The ACT Profile 50 RGBAL has 3-pin DMX signal IN and OUT connectors.

The pin assignment is as follows: pin 1 (ground), pin 2 (-), pin 3 (+).

Devices on a serial data link must be daisy-chained in a single line. The number of devices that you can control on one data link is limited by the combined number of the DMX channels of the connected devices and the 512 channels available in one DMX universe.

To comply with the TIA-485 standard, no more than 32 devices should be connected on one data link. In order to connect more than 32 devices on one data link, you must use a DMX optically isolated splitter/booster, otherwise this may result in deterioration of the DMX signal.

Notes:

- Maximum recommended DMX data link distance: 300 m
- Maximum recommended number of devices on a DMX data link: 32 devices

5.3.2. DMX Cables

Shielded twisted-pair cables with 3-pin XLR connectors must be used for a reliable DMX connection. You can purchase DMX cables directly from your Highlite International dealer or make your own cables.

If you use XLR audio cables for DMX data transmission, this may lead to signal degradation and unreliable operation of the DMX network.

When you make your own DMX cables, make sure that you connect the pins and wires correctly as shown in Fig. 24.

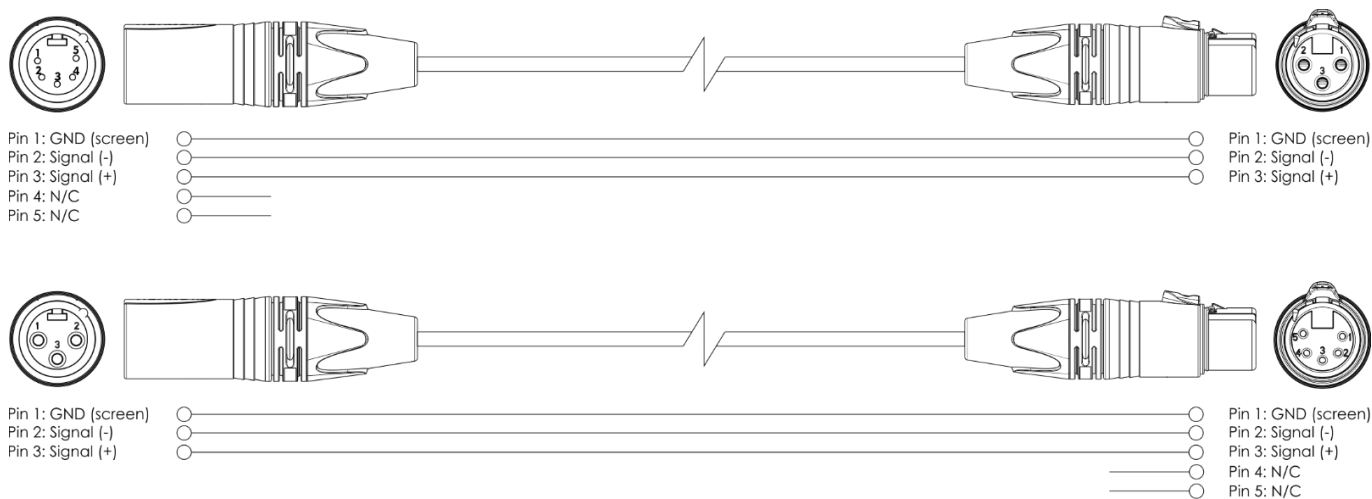

Fig. 24

5.3.3. DMX Linking

To connect multiple devices on one DMX data link, follow the steps below:

- 01) Connect the DMX OUT connector on the lighting controller to the DMX IN connector on the first device with a 3-pin DMX cable.
- 02) Connect the DMX OUT connector on the first device to the DMX IN connector on the second device with a 3-pin DMX cable.
- 03) Repeat step 2 to connect all devices in a daisy-chain as shown in Fig. 25.
- 04) Connect a DMX terminator (120 Ω resistor) to the DMX OUT connector of the last device on the data link.

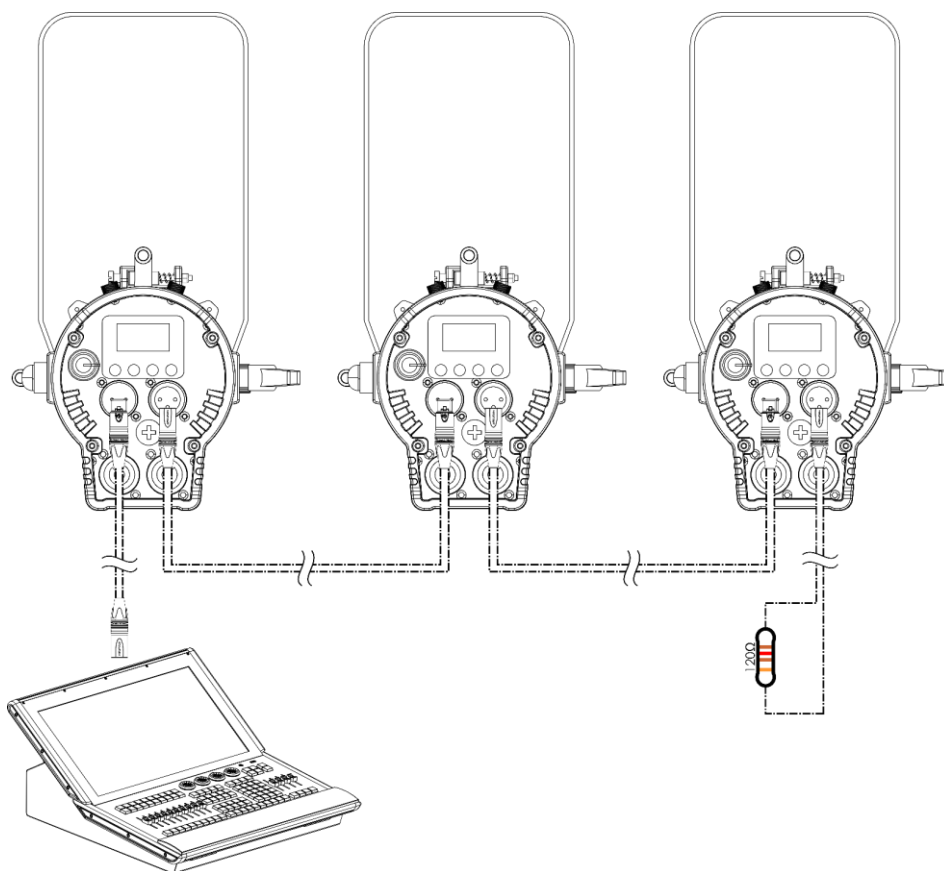

Fig. 25

5.3.4. DMX Addressing

In a setup with multiple devices, make sure that you set the DMX starting address of each device correctly. The ACT Profile 50 RGBAL has 3 personalities: 5, 8 and 12 channels.

If you want to connect multiple devices on one data link and use them in 12-channel mode, for example, follow the steps below:

- 01) Set the starting address of the 1st device on the data link to 1 (001).
- 02) Set the starting address of the 2nd device on the data link to 13 (013), as $1 + 12 = 13$.
- 03) Set the starting address of the 3rd device on the data link to 25 (025) as $13 + 12 = 25$.
- 04) Continue assigning the starting addresses of the remaining devices by adding 12 to the previous number each time.

Make sure that you do not have any overlapping channels in order to control each ACT Profile 50 RGBAL correctly. If two or more devices are addressed similarly, they will work similarly.

6. Operation

6.1. Safety Instructions for Operation



Attention

This device must be used only for the purposes it is designed for.

This device is intended for use as a professional theater spotlight and is suitable for indoor use only. This device is not suitable for households or general lighting.

Any other use, not mentioned under intended use, is regarded as non-intended and incorrect use.



Attention

Power supply

Before connecting the device to the power supply, make sure that the current, voltage and frequency match the input voltage, current and frequency specified on the information label on the device.

6.2. Control Modes

The ACT Profile 50 RGBAL can be operated with a DMX controller and as a stand-alone device.

The ACT Profile 50 RGBAL supports the following control modes:

- DMX-512: 5, 8 and 12-channel mode
- Stand-alone: Manual and remote operation

For more information about how to connect the devices, refer to **5. Setup** on pages 20–22.

To operate the device with a DMX controller:

You can operate the device manually as a stand-alone device in 2 ways:

- from the control panel and the menu
- with the **Manual dimmer / Preset Color control (19)**. See **6.6.2.1. Function Mode** on page 29 for more information.

To operate the device manually from the control panel and the menu:

- 01) Select Manually Defined in the Mode pop-up submenu. See **6.6.2.1. Function Mode** on page 29 for more information.
- 02) Adjust the dimmer and shutter values in the Manually Defined submenu. See **6.7. Manual Operation** on page 32 for more information.

To operate the device with a DMX controller:

- 01) Set the DMX starting address of the device in the DMX Address menu. See **6.6.1.1. DMX Address** on page 27 for more information.
- 02) Select the behavior of the device in case there is no DMX signal in the DMX Fail pop-up submenu. See **6.6.1.3. DMX Fail** on page 28.

Select the DMX channel mode in the DMX channel mode menu. See **6.6.1.2. DMX Channel Mode** on page 28 for more information. See **6.8. DMX Channels** on pages 33–34 for complete overview of all DMX channels.

6.3. Control panel

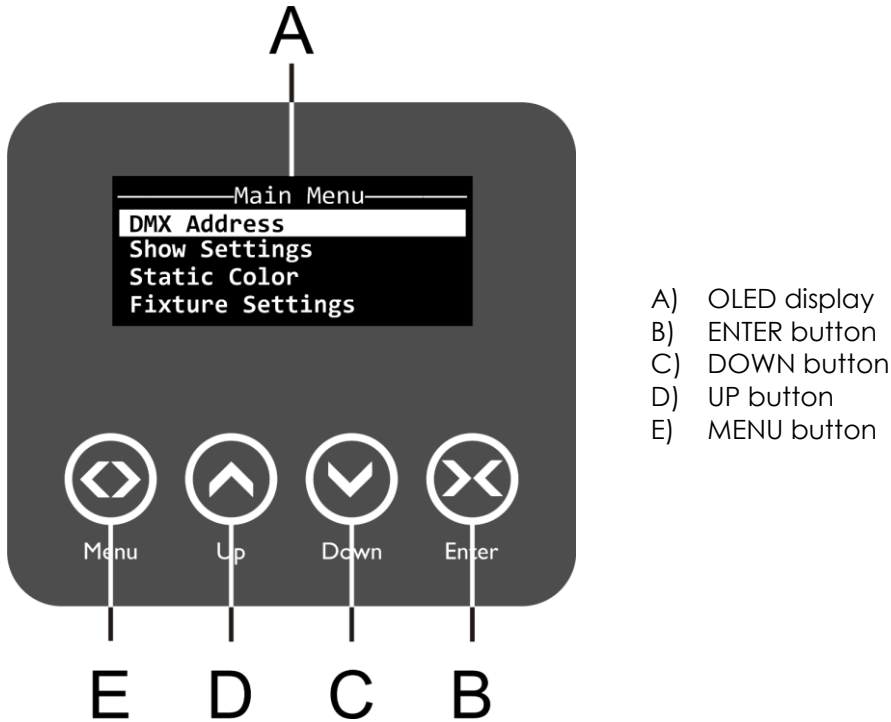
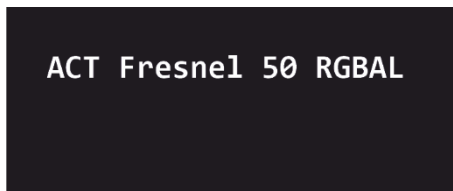

Fig. 26

- Use the **MENU** button to exit the current submenu, to return to the Main Menu and to return to the start screen.
- Use the **UP/DOWN** buttons to navigate through the menus or to increase/decrease numeric values.
- Use the **ENTER** button to open the desired menu, to confirm or to set the currently selected value.

6.4. Start-up

Upon start-up the display shows a splash screen with the product name followed by a start screen.



The start screen provides information about the control and operation modes of the device and the temperature of the LEDs, for example:

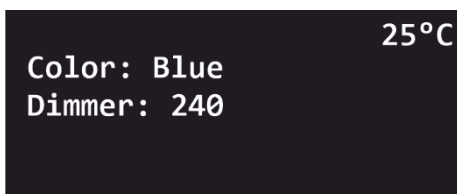

Manual operation (color: blue, dimmer: 240)



5-channel DMX mode with starting address 001

Note:

If no button is pressed, after 20 seconds of inactivity the display will turn off. Press any button to turn the display on. See **6.6.5. Display Settings** on page 31 for more information.

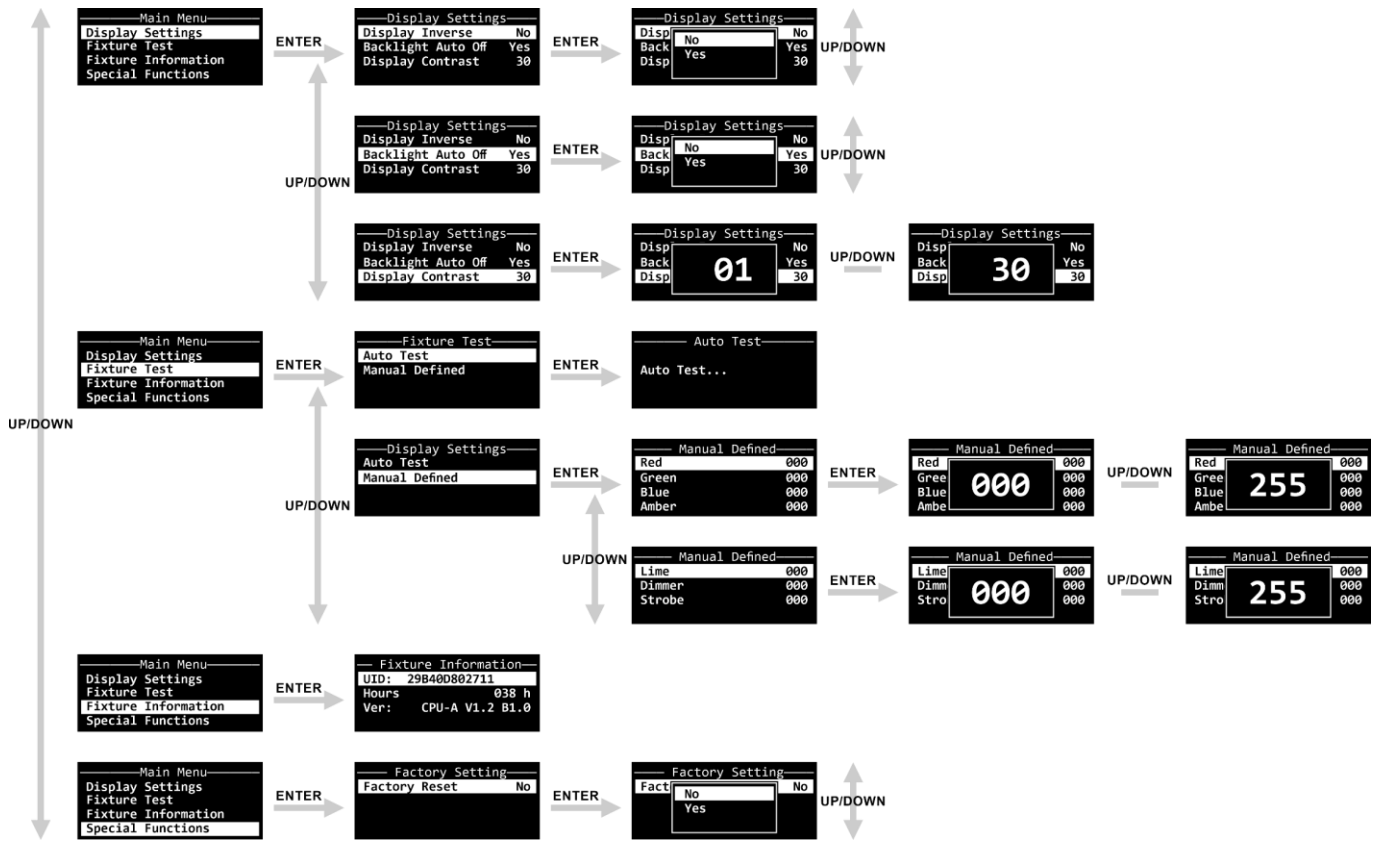

6.6. Main Menu Options

The main menu has the following options:

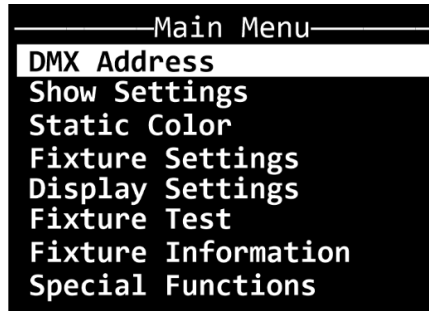

- 01) Press the **UP/DOWN** buttons to navigate through the main menu.
- DMX Address: See **6.6.1. DMX Functions** for more information.
 - Show Settings: See **6.6.2. Show Settings** for more information.
 - Static Color: See **6.6.3. Static Color** for more information.
 - Fixture Settings: See **6.6.4. Fixture Settings** for more information.
 - Display Settings: See **6.6.5. Display Settings** for more information.
 - Fixture Test: See **6.6.6. Fixture Test** for more information.
 - Fixture Information: See **6.6.7. Fixture Information** for more information.
 - Special Functions: See **6.6.8. Special Functions** for more information.
- 02) Press the **ENTER** button to open the submenus.

6.6.1. DMX Functions

In this menu you can configure the DMX settings of the device.

- 01) Press the **UP/DOWN** buttons to select one of the following 4 options:

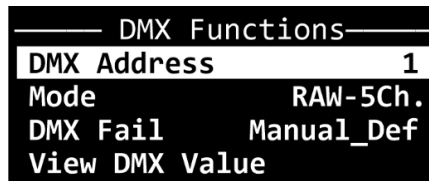

- DMX Address: See **6.6.1.1. DMX Address** for more information.
 - DMX Channel Mode: See **6.6.1.2. DMX Channel Mode** for more information.
 - DMX Fail: See **6.6.1.3. DMX Fail** for more information.
 - View DMX Value: See **6.6.1.4. View DMX Value** for more information.
- 02) Press the **ENTER** button to confirm.

6.6.1.1. DMX Address

In this pop-up submenu you can set the DMX starting address of the device.

- 01) Press the **UP/DOWN** buttons to select the starting DMX address of the device. The selection range is between 001 and 512.



- 02) Press the **ENTER** button to confirm.

6.6.1.2. DMX Channel Mode

In this pop-up submenu you can select the DMX channel mode.

01) Press the **UP/DOWN** buttons to select the DMX channel mode. There are 3 options available:

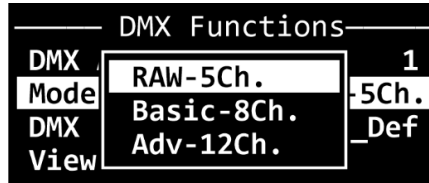

- RAW-5Ch: 5-channel mode
- Basic-8Ch: 8-channel mode
- Adv-12Ch: 12-channel mode

02) Press the **ENTER** button to confirm.

6.6.1.3. DMX Fail

In this pop-up submenu you can determine the behavior of the device in case there is no DMX signal.

01) Press the **UP/DOWN** buttons to select one of the following 3 options:

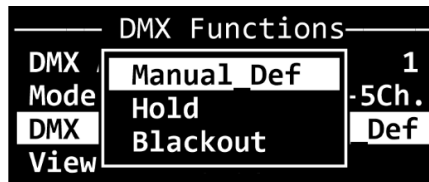

- Manually Defined: The device will use the manually selected dimmer value. See **6.6.6.1. Manual Defined** on page 29 for more information.
- Hold: The device will use the last DMX signal received correctly.
- Blackout: The device will black out the light output.

02) Press the **ENTER** button to confirm.

6.6.1.4. View DMX Value

In this submenu you can view the currently selected DMX value for each DMX channel.

Press the **UP/DOWN** buttons to scroll through the options:



Depending on the selected DMX channel mode in the DMX Channel Mode submenu, you can see the following values:

- in 5- channel DMX mode: red, green, blue, amber, lime;
- in 8- channel DMX mode: red, green, blue, amber, lime, CCT, dimmer and strobe;
- in 12-channel DMX mode: red, green, blue, amber, lime, color macros, CCT, dimmer, dimmer fine, shutter, macro auto and macro speed.

6.6.2. Show Settings

In this menu you can select the operation mode, the built-in chase and the speed.

01) Press the **UP/DOWN** buttons to scroll through the following 3 options:

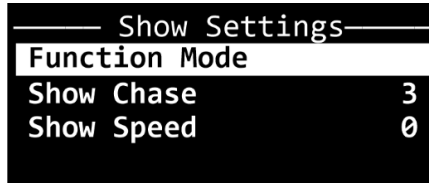

- Mode: Select how to operate the device manually. See **6.6.2.1. Function Mode** for more information.
- Show Chase: Select the built-in chase. See **6.6.2.2. Show Chase** for more information.
- Show Speed: Select the speed. See **6.6.2.3. Show Speed** for more information.

02) Press the **ENTER** button to confirm.

6.6.2.1. Function Mode

In this pop-up submenu menu you can select how to operate the device manually.

01) Press the **UP/DOWN** buttons to select one of the following 3 options:

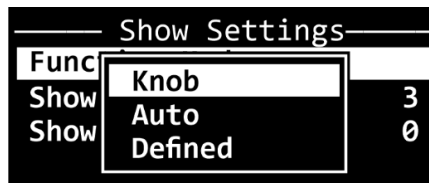

- Knob: You can control the device manually with the **Manual dimmer / Preset Color control (19)**. See **6.7. Manual Operation** on page 32 for more information about the 21 manual Preset colors.
- Auto: The device runs one of the built-in chases.
- Manually defined: You can control the device manually via the control panel and the menu.

02) Press the **ENTER** button to confirm.

6.6.2.2. Show Chase

In this pop-up submenu menu you can select one of the 9 built-in chases.

01) Press the **UP/DOWN** buttons to select the built-in chase. The adjustment range is 001–009.



02) Press the **ENTER** button to confirm.

6.6.2.3. Show Speed

In this pop-up submenu menu you can select the speed of the built-in chase.

01) Press the **UP/DOWN** buttons to set the speed. The adjustment range is 00–99.



02) Press the **ENTER** button to confirm.

6.6.3. Static Color

In this menu you can select one of the 64 color macros and OFF.

01) Press the **UP/DOWN** buttons to select one of the 65 options:



To view all available options, see the **Static Colors** of CH6 of the 12-channel mode on pages 33–34.
 02) Press the **ENTER** button to confirm.

6.6.4. Fixture Settings

In this menu you can adjust the dimmer curve and speed.

01) Press the **UP/DOWN** buttons to select one of the following 3 options:

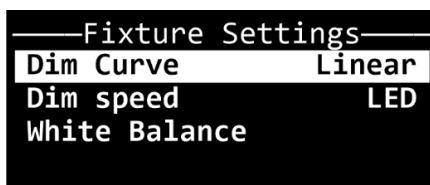

- Dimmer Curve: There are 4 options available: Linear, Square Law, Inverse Square Law and S-Curve

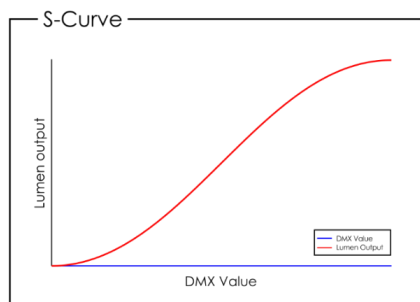
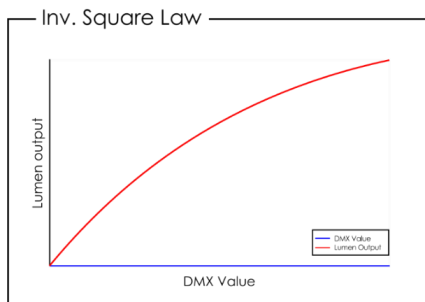
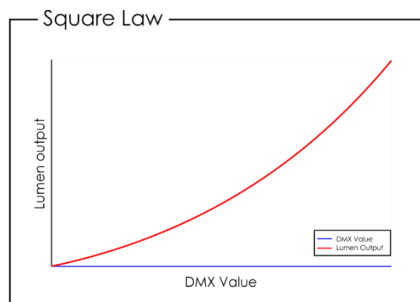
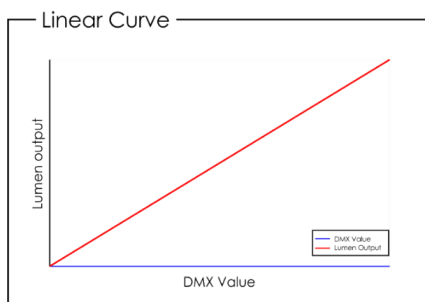

- Dimmer Speed: There are 2 options available: LED (instant dimming without delay) and Halogen (delayed dimming, imitating the behavior of a halogen lamp)
- White Balance: You can adjust the white balance of the LEDs through adjusting the values of the red, green, and blue colors. The adjustment range is 125–255

02) Press the **ENTER** button to confirm.

6.6.5. Display Settings

In this menu you can adjust the display settings of the device.

01) Press the **UP/DOWN** buttons to select one of the following 3 options:



- Display Inverse: The OLED display will be rotated by 180° (NO/YES)
- Backlight Auto Off: The backlight of the OLED display will not turn off automatically after 60 seconds of inactivity (NO/YES)
- Display Contrast: The adjustment range is 01–30 (from low to high contrast)

02) Press the **ENTER** button to confirm and open the pop-up submenu where you can adjust the settings.

03) Press the **UP/DOWN** buttons to select the desired setting.

04) Press the **ENTER** button to confirm.

6.6.6. Fixture Test

In this menu you can perform a test of the parameters of the device and manually adjust the color and the dimmer and strobe values.

01) Press the **UP/DOWN** buttons to select one of the following 2 options:

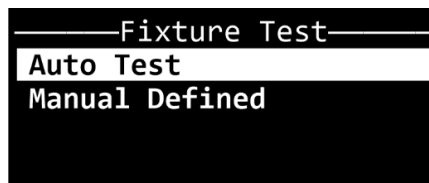

- Auto Test: The device performs an auto test of its parameters
- Manual Defined: See **6.6.6.1. Manual Defined** for more information

02) Press the **ENTER** button to confirm.

6.6.6.1. Manual Defined

In this submenu you can manually adjust the colors, the dimmer and the strobe.

01) Press the **UP/DOWN** buttons to scroll through following options: red, green, blue, amber, lime, dimmer, and strobe.

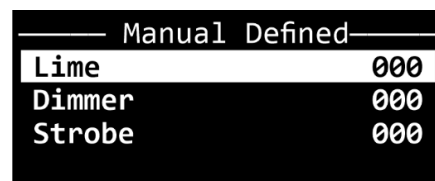
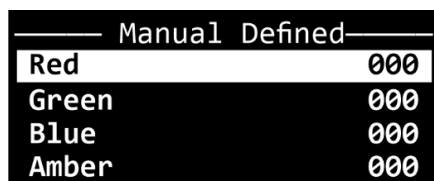

02) Press the **ENTER** button to confirm and open the respective pop-up submenu where you can adjust the values.

03) Press the **UP/DOWN** buttons to adjust the values. The adjustment range is between 0 and 255.

04) Press the **ENTER** button to confirm.

6.6.7. Fixture Information

In this menu you can view the UID (No function), the LED operating hours and the firmware version of the device.

Press the **UP/DOWN** buttons to select one of the following 3 options:

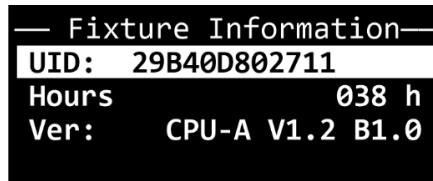

- **UID:** The display shows the device UID. See **6.9. RDM Information** on page 35 for more information
- **Fixture Use Time:** Provides information about the total hours of operation of the LEDs
- **Firmware Version:** Shows the current firmware version

6.6.8. Special Functions

In this menu you can reset the settings of the device to the default factory settings.

01) Press the **ENTER** button to open the pop-up submenu for the factory settings:

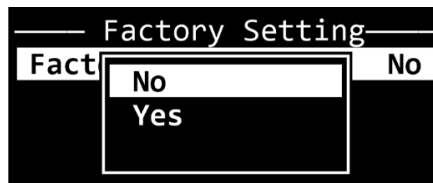

- 02) Press the **UP/DOWN** buttons to select between NO and YES. If you select YES, the device's settings will be reset to the default factory settings.
- 03) Press the **ENTER** button to confirm.

6.7. Manual Operation

To operate the device manually with the **Manual dimmer / Preset Color control (19)**:

- 01) Select **Knob** in the Mode pop-up submenu. See **6.6.2.1. Function Mode** on page 29 for more information.
- 02) Exit the submenu and return to the start screen. The start screen shows:

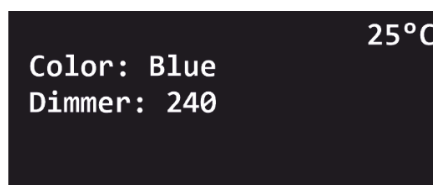

- 03) To switch between the Manual dimmer and Preset Color mode press the **Manual dimmer / Preset Color control (19)**.
- 04) Turn the **Manual dimmer / Preset Color control (19)** to adjust the intensity of the light. The adjustment range is between 0 and 255 (from 0 to 100 %). The current value of the dimmer is displayed on the screen.
- 05) Turn the **Manual dimmer / Preset Color control (19)** to select one of the preset color macros. The following options are available: red, green, blue, amber, lime, yellow, light blue, purple, 2800 K, 3200 K, 3600 K, 4000 K, 4400 K, 4800 K, 5200 K, 5600 K, 6000 K, 6600 K, 7200 K, 8000 K and 10000 K. The current color is displayed on the screen.

Note:

- The **Manual dimmer / Preset Color control (19)** is functional, even if you do not exit the menu and return to the start screen.
- It is not possible to add strobe effect in this mode.

6.8. DMX Channels

6.8.1. 5 Channels, 8 Channels, 12 Channels

5 CH	8 CH	12 CH	Function	Value	Setting
1	1	1	Red Dimmer	000–255	From low to high intensity (0–100 %)
2	2	2	Green Dimmer	000–010	From low to high intensity (0–100 %)
3	3	3	Blue Dimmer	000–255	From low to high intensity (0–100 %)
4	4	4	Amber Dimmer	000–255	From low to high intensity (0–100 %)
5	5	5	Lime Dimmer	000–255	From low to high intensity (0–100 %)
				000	Off
				001–004	Pale Lavender
				005–008	Quarter Blue
				009–012	Yellow
				013–016	Daylight Blue
				017–020	Light Pink
				021–024	Light Amber
				025–028	Half Minus Green
				029–032	Quarter New Color Blue
				033–036	Oklahoma Yellow
				037–040	Spring Yellow
				041–044	Pale Rose
				045–048	Medium Bastard Amber
				049–052	Lavender Tint
				053–056	English Rose
				057–060	Dark Pink
				061–064	Mist Blue
				065–068	Congo Blue
				069–072	Steel Blue
				073–076	Lee Green
				077–080	Fire
				081–084	Orange
				085–088	Medium Amber
				089–092	Hampshire Rose
		6	Static Colors	093–096	Light Pink
				097–100	Lee Yellow
				101–104	Deep Lavender
				105–108	Lavender Tint
				109–112	Light Lavender
				113–116	Old Steel Blue
				117–120	Madge
				121–124	Rose Purple
				125–128	Rose Pink
				129–132	Lagoon Blue
				133–136	Follies Pink
				137–140	Mist Blue
				141–144	Magical Magenta
				145–148	Pale Yellow
				149–152	Summer Blue
				153–156	Steel Green
				157–160	Half Shanklin Frost
				161–164	Regal Blue
				165–168	Special Pale Lavender
				169–172	Liberty Green
				173–176	Lilac Tint
				177–180	Leef Fluorescent 4300K
				181–184	No Color Blue
				185–188	Terry Red
			189–192	Lighter Blue	

5 CH	8 CH	12 CH	Function	Value	Setting
				193–196	Waterfront Green
				197–200	2800 K (CRI 91)
				201–204	3200 K (CRI 93)
				205–208	3400 K (CRI 92)
				209–212	3600 K (CRI 93)
				213–216	3800 K (CRI 93)
				217–220	4000 K (CRI 91)
				221–224	4200 K (CRI 93)
				225–228	4400 K (CRI 93)
				229–232	4800 K (CRI 92)
				233–236	5600 K (CRI 91)
				237–240	6000 K (CRI 93)
				241–244	6600 K (CRI 91)
				245–248	7200 K (CRI 90)
				249–252	7600 K (CRI 91)
				253–255	8000 K (CRI 91)
				000–009	Dimming mode (CH1–CH5)
				010–024	2800 K (CRI 94)
				025–039	3200 K (CRI 93)
				040–054	3600 K (CRI 93)
				055–069	4000 K (CRI 91)
				070–084	4400 K (CRI 93)
				085–099	4800 K (CRI 92)
				100–114	5200 K (CRI 92)
				115–129	5600 K (CRI 91)
				130–144	6000 K (CRI 93)
				145–159	6600 K (CRI 91)
				160–174	7200 K (CRI 90)
				175–189	8000 K (CRI 91)
				190–255	10000 K (CRI 92)
	6	7	CCT		
	7	8	Master Dimmer	000–255	From low to high intensity (0–100 %)
		9	Dimmer Fine	000–255	From low to high intensity (0–100 %)
	8	10	Shutter	000–031	Shutter closed
				032–063	Shutter open
				064–095	Linear strobe, from low to high frequency (0–25 Hz)
				096–127	Shutter open
				128–159	Pulse strobe, from slow to fast
				160–191	Shutter open
				192–223	Random strobe, from slow to fast
				224–255	Shutter open
		11	Built-in Programs	000–003	No function
				004–127	Color 1–32
				128–191	Color fade 1–16
				192–255	Color change 1–16
		12	Program Speed	000–255	From low to high intensity (0–100 %)

Note:

Make sure that the shutter (strobe) channel is open in order to use the dimmer.

6.9. RDM Information

This device support RDM. Refer to **6.9.2 Supported RDM PIDs (Parameter IDs)** for more information.

6.9.1. RDM Details

- Responder: 29B4:0D8xxxxx
- Manufacturer's ID: Showtec (Highlite International B.V.)
- Manufacturer Label: Showtec
- Model Description: ACT Profile 50 RGBAL
- Model ID: 216
- Device Label: ACT Profile 50 RGBAL

Note:

An RDM responder ID consists of 3 parts:

- 1st part – 4 digits – Manufacturer's ID
- 2nd part – 3 digits – Model ID
- 3rd part – 5 digits – Unique ID

The RDM responder IDs of all products of Highlite International start with the same 4 digits. The first 7 digits of the RDM responder ID for each model are the same. The last 5 digits are different for each device.

6.9.2. Supported RDM PIDs (Parameter IDs)

Parameter ID	Value	Required	GET	SET
SUPPORTED_PARAMETERS	0x0050	*	*	
DEVICE_MODEL_DESCRIPTION	0x0080		*	
MANUFACTURER_LABEL	0x0081		*	
DEVICE_LABEL	0x0082		*	*
DMX_PERSONALITY	0x00E0		*	*
DMX_PERSONALITY_DESCRIPTION	0x00E1		*	
DMX_START_ADDRESS	0x00F0	*	*	*
DEVICE_HOURS	0x0400		*	*

7. Troubleshooting

This troubleshooting guide contains solutions to problems which can be carried out by an ordinary person. The device does not contain user-serviceable parts.

Unauthorized modifications to the device will render the warranty void. Such modifications may result in injuries and material damage.

Refer servicing to instructed or skilled persons. Contact your Highlite International dealer in case the solution is not described in the table.

Problem	Probable cause(s)	Solution
The device does not function at all	No power to the device	<ul style="list-style-type: none"> Make sure power is switched on and cables are plugged in
	Main fuse is blown	<ul style="list-style-type: none"> Replace the fuse. See 8.3.1. Replacing the Fuse on page 38
The device responds erratically	The factory settings of the device are changed	<ul style="list-style-type: none"> Reset the device's parameters to the default factory settings. See 6.6.8. Special Functions on page 32
The device does not respond to DMX control	The controller is not connected	<ul style="list-style-type: none"> Connect the controller
	The signal is reversed. The 3-pin DMX OUT of the controller does not match the DMX IN of the device	<ul style="list-style-type: none"> Install a phase-reversing cable between the controller and the device
	The controller is defective	<ul style="list-style-type: none"> Try using another controller
The device responds erratically to DMX control	Bad data link connection	<ul style="list-style-type: none"> Examine connections and cables. Correct poor connections. Repair or replace damaged cables
	The data link is not terminated with a 120 Ω termination plug	<ul style="list-style-type: none"> Insert a termination plug in the DMX OUT connector of the last device on the link
	Incorrect addressing	<ul style="list-style-type: none"> Check address settings and correct, if necessary
	In case of a setup with multiple devices, one of the devices is defective and disturbs data transmission on the link	<ul style="list-style-type: none"> To find out the defective device, bypass one device at a time until normal operation is restored
No light or LEDs cut out intermittently	LEDs are damaged	<ul style="list-style-type: none"> Disconnect the device and contact your Highlite International dealer
	The power supply settings do not match local AC voltage and frequency	<ul style="list-style-type: none"> Disconnect the device. Check the settings and correct, if necessary

8. Maintenance

8.1. Safety Instructions for Maintenance



DANGER
Electric shock caused by dangerous voltage inside

Disconnect power supply before servicing or cleaning.

8.2. Preventive Maintenance



Attention
Before each use, examine the device visually for any defects.

Make sure that:

- All screws used for installing the device or parts of the device are tightly fastened and are not corroded.
- The safety devices are not damaged.
- There are no deformations on housings, fixations and installation points.
- The lens is not cracked or damaged.
- The power cables are not damaged and do not show any material fatigue.

8.2.1. Basic Cleaning Instructions

The external lens of the device must be cleaned periodically in order to optimize the light output. The cleaning schedule depends on the conditions at the site where the device is installed. When smoke or fog machines are used at the site, the device will need more frequent cleaning. On the other hand, if the device is installed in well-ventilated area, it will need less frequent cleaning. To establish a cleaning schedule, examine the device at regular intervals during the first 100 hours of operation.

To clean the device, follow the steps below:

- 01) Disconnect the device from the electrical power supply.
- 02) Allow the device to cool down for at least 15 minutes.
- 03) Remove the dust collected on the external surface with dry compressed air and a soft brush.
- 04) Clean the lens with a damp cloth. Use a mild detergent solution.
- 05) Dry the lens carefully with a lint-free cloth.
- 06) Clean the DMX and other connections with a damp cloth.



Attention

- Do not immerse the device in liquid.
- Do not use alcohol or solvents.
- Make sure that the connections are fully dry before connecting the device to the power supply and to other devices.

8.3. Corrective Maintenance

The device does not contain user-serviceable parts. Do not open the device and do not modify the device.

Refer repairs and servicing to instructed or skilled persons. Contact your Highlite International dealer for more information.

8.3.1. Replacing the Fuse



DANGER
Electric shock caused by short-circuit

- Do not bypass the thermostatic switch or fuses.
- For replacement use fuses of the same type and rating only.

Power surges, short-circuit or incorrect electrical power supply may cause a fuse to burn out. If the fuse burns out, the device will not function anymore. If this happens, follow the steps below:

- 01) Disconnect the device from the electrical power supply.
- 02) Allow the device to cool down for at least 15 minutes.
- 03) Loosen the fuse cover with a screwdriver and remove the fuse holder.
- 04) If the fuse is brown or unclear, it is burned out. Remove the old fuse.
- 05) Insert a new fuse in the fuse holder. Make sure that the type and the rating of the replacement fuse are the same as the ones specified on the information label of the product.
- 06) Replace the fuse holder in the opening and tighten the fuse cover.

9. Deinstallation, Transportation and Storage

9.1. Instructions for Transportation



WARNING

Incorrect deinstallation can cause serious injuries and damage of property.

- Let the device cool down before dismounting.
- Disconnect power supply before deinstallation.
- Always observe the national and site-specific regulations during deinstallation and derigging of the device.
- Wear personal protective equipment in compliance with the national and site-specific regulations.

9.2. Instructions for Deinstallation

- Use the original packaging to transport the device, if possible.
- Always observe the handling instructions printed on the outer carton box, for example: "Handle with care", "This side up", "Fragile".

9.3. Storage

- Clean the device before storing. Follow the cleaning instructions in chapter **8.2.1. Basic Cleaning Instructions** on page 37.
- Store the device in the original packaging, if possible.

10. Disposal

Correct disposal of this product



Disposal of Old Electrical and Electronic Equipment (Applicable in the European Union and other European countries with separate collection systems)

This symbol on the product, its packaging or documents indicates that the product shall not be treated as household waste. Dispose of this product by handing it to the applicable collection point for the recycling of electrical and electronic equipment. This is to avoid environmental damage or personal injury due to uncontrolled waste disposal. For more detailed information about recycling of this product contact the local authorities or the authorized dealer.

11. Approval



Check the respective product page on the website of Highlite International (www.highlite.com) for an available declaration of conformity.



©2023 Showtec