

PUBLIC ADDRESS / AMPLIFIERS / MONO

MAZ-0604

MULTI-CHANNEL AND MATRIX PUBLIC ADDRESS AMPLIFIER



- ✔ Multi-channel and matrix public address amplifier
- ✔ Matrix of assignment of each input to different outputs
- ✔ 4 x output zones with amplifier and independent volume control
- ✔ Gran fiabilidad, fácil instalación y bajo mantenimiento

ESPECIALLY RECOMMENDED IN:



Hospitality



Education



All sectors



+ Info:

<https://fonestar.com/MAZ-0604>

DESCRIPTION

Matrix and multi-channel amplifier. Amplifier for installations with loudspeaker zones, it can play different music in each zone and send each input to different zones, creating an audio system with different music in each zone. It provides great flexibility thanks to its matrix function and four output channels with independent amplifier. Each input can be routed to different outputs in a simple and visual way, with the assignment buttons on each input channel. The different output zones can play a different music programme and have independent volume. It has a speaker output and line level signal in case additional amplification is required. Each zone will be able to enjoy its own personalised music programme. The loudspeaker outputs are low impedance and 100 V line outputs for PA installations where many loudspeakers are required. Priority microphone inputs allow for alerts to be given by automatically attenuating the music and returning to normal level. It also has a telephone switchboard line output input with the same function. The amplifier offers high reliability, easy installation and low maintenance. It has overload, short-circuit and temperature protections as well as temperature-controlled variable cooling. Designed for use in public address installations with different audio for each zone, which can share announcements or music, such as schools, offices, industrial facilities, retail and leisure areas.

TECHNICAL CHARACTERISTICS

FEATURES	Matrix and multi-channel amplifier. Allocation matrix of 5 input channels to 4 output zones 4 zones with loudspeaker and line output. Zones with independent volume control. Priority paging by signal level and contact closure.
POWER	4 x 60 W RMS
RESPONSE	50-20,000 Hz (-3 dB)
DISTORTION	THD+N: < 1%
S/N RATIO	Mic >60 dB, Aux/Line >75 dB
PROTECTIONS	Over-current, overload, overload, temperature and short circuit Temperature-controlled ventilation cooling
INPUTS	CH 1, 2 and 3 balanced mic/line with 15V Phantom. Combo connector (XLR + jack 6.3 mm) Microphone signal level: 2.8 mV RMS (-50 dBV) / 600 Ohm Line signal level: 280 mV RMS (-15 dBV) / 15.000 Ohm CH 4 a 5 auxiliary. 2 x RCA connector. Signal level: 110 mV RMS (-18 dBV) / 50.000 Ohm Auxiliary AUX. 3.5 mm jack connector 25 mV RMS (-24 dBV) signal level Tel. paging. Connector screw Terminals 316 mV RMS (-30 dBV) / 600 Ohm signal level
OUTPUTS	4 x balanced lines zones 1 to 4. Connector screw Terminals 1 V RMS signal level 1 x headphone monitor. Connector: 6.3 mm. 1 x monitor on rear panel. Connector: screw terminals. 900 mV RMS / 600 Ohm signal level and 1 W / 8 Ohm for loudspeaker
IMPEDANCE	4 zones: 4 and 8 Ohm and 100, 70 and 25 V lines, screw terminals
FUNCTIONS	Input priority: CH 1 input and Tel. paging with priority over all other inputs by signal level Inputs CH 1, 2, 3 and Tel. paging with priority over auxiliary inputs by contact closure



+ Info:

<https://fonestar.com/MAZ-0604>

CONTROLS	CH 1 to 5: gain, bass, treble, volume and zone assignment Tel. paging: volume and zone selector Zones 1 to 4: volume and monitor selector Monitor: volume Auxiliary: volume
TEMPERATURE	Operation: -20° ~ 45°C Storage: -20° ~ 40°C
MAXIMUM HUMIDITY	0.7
POWER SUPPLY	230/115 V AC 50/60 Hz Power consumption: 380 W FUSE 230 V AC 3.15 A / 115 V 6.3 A
DIMENSIONS	420 x 133 x 375 mm depth. 3 U 19" rack
WEIGHT	12.8 kg
ACCESSORIES	Rack mounts



+ Info:
<https://fonestar.com/MAZ-0604>

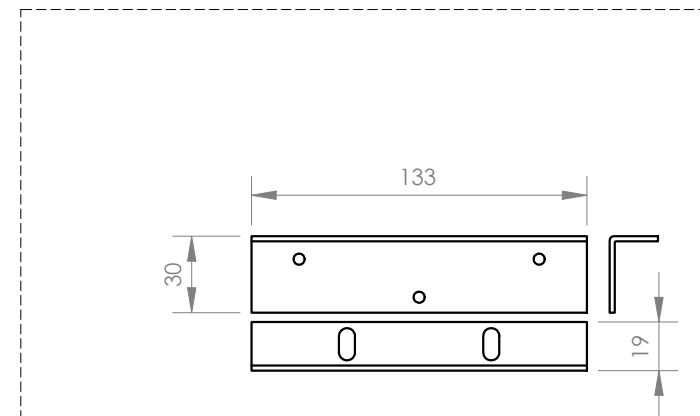
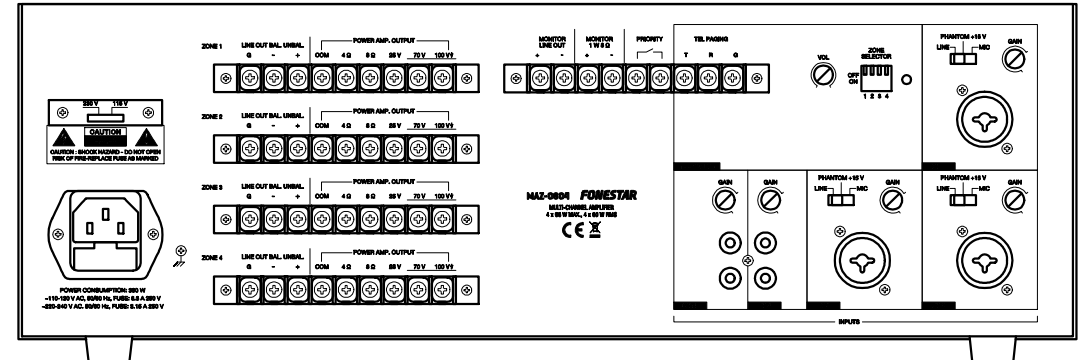
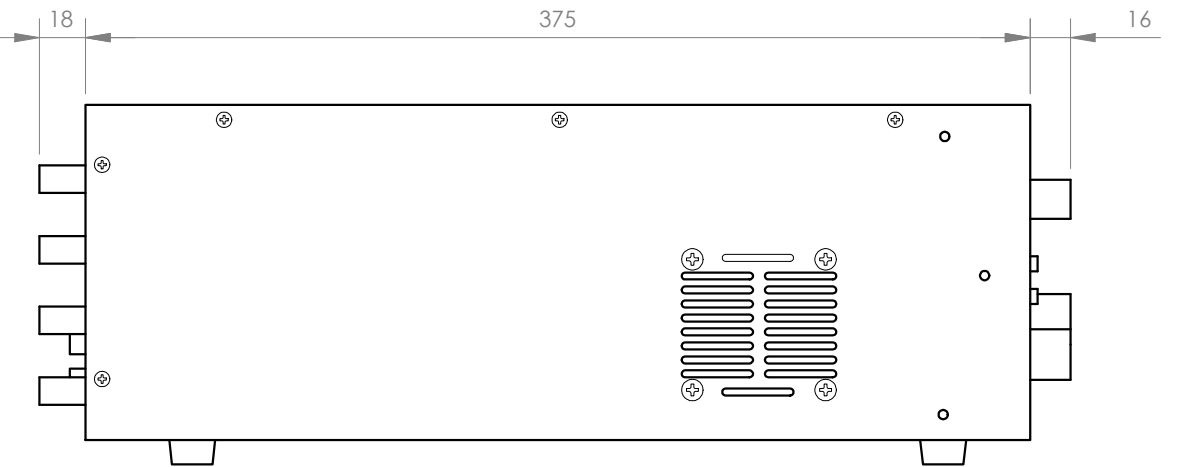
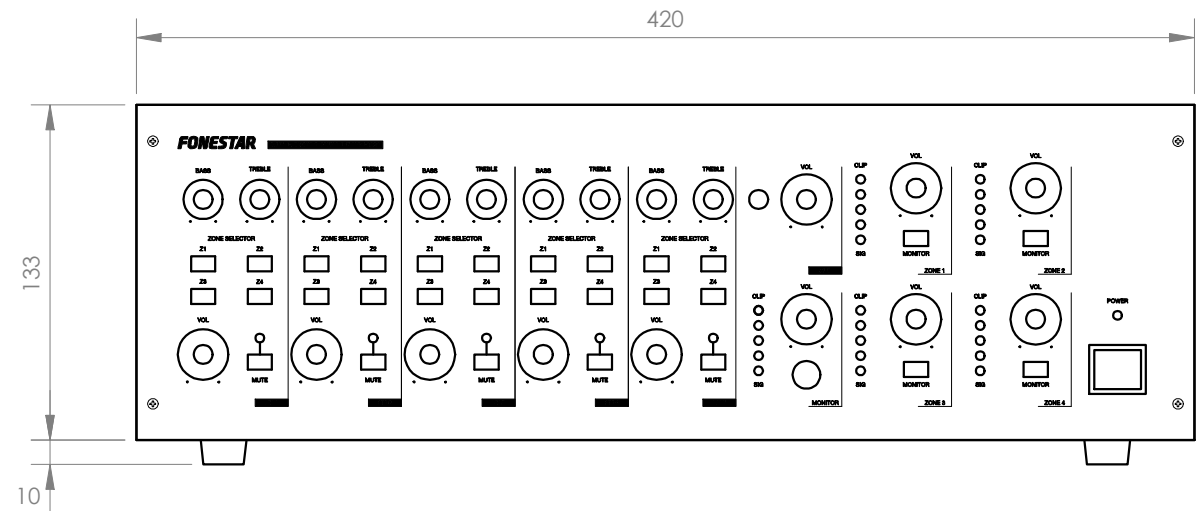

FONESTAR	Model	Description	Units	Scale
	MAZ-0604	MULTI-CHANNEL AND MATRIX PUBLIC ADDRESS AMPLIFIER	mm	1:3