



# MSC-12

## WIRELESS IN EAR MONITOR MICROPHONE SYSTEMS RECHARGE DOCKING STATION



### DESCRIPTION

- Wireless in ear monitor microphone systems recharge docking station.

### CONTROLS AND FUNCTIONS

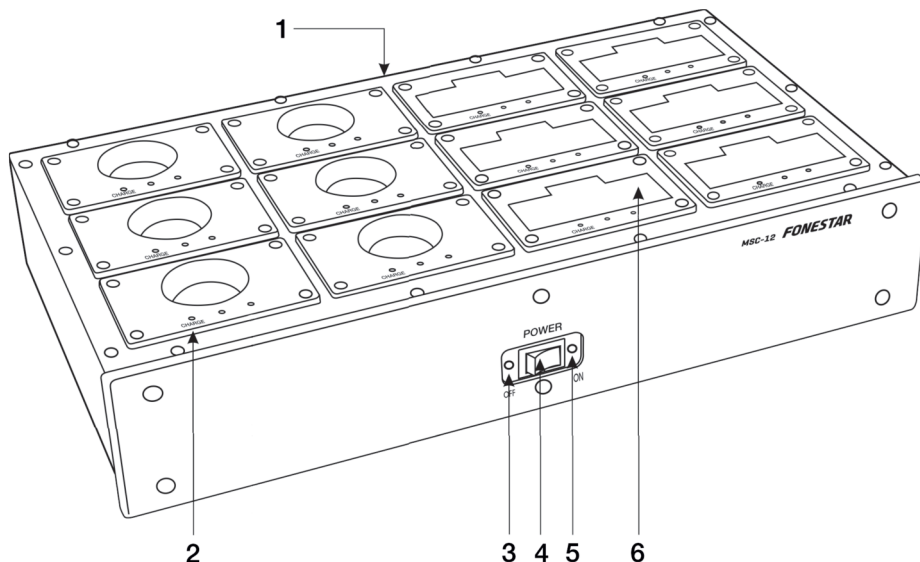

- 1.- Power supply connection for the mains adapter provided.
- 2.- **CHARGE:** LED battery charging process indicator. Flashes in red during the charging process and remains lit when fully charged.
- 3.- **OFF:** LED indicator which lights up red when the device is connected to the power supply.
- 4.- Button to switch on/off the recharge docking station.
- 5.- **ON:** LED power indicator. It lights up green when the recharge docking station is switched on.
- 6.- Socket for recharging microphones or wireless receivers.

### TECHNICAL SPECIFICATIONS

	MSC-12
<b>CHARACTERISTICS</b>	Wireless in ear monitor microphone system recharge docking station. For recharging 12 microphones or receivers simultaneously. For recharging the rechargeable batteries in the models: MSHT-40M, MSHT-45P and RI-840.
<b>INDICATORS</b>	LED power indicator LED charge process indicator LED charge complete indicator
<b>POWER SUPPLY</b>	12 V DC, 3 A, with adapter included
<b>DIMENSIONS</b>	355 x 69 x 202 mm depth

**WARRANTY:** 2 years against any manufacturing defect, accompanied by proof of purchase. Does not cover damage caused by subsequent breakages



FONESTAR is a member of ECOEMBALAJES ESPAÑA, S.A. "ECOEMBES", with number 03497 and all our products carry the symbol, backed by our membership and subscription to the above mentioned organization with the recycling and subsequent management of our packaging.  
 FONESTAR is registered in the RAEE (Registro de Aparatos Eléctricos y Electrónicos) in a special section REI (Registro de establecimientos Industriales), with the entry number 001851.  
 FONESTAR S.A. - NIF A28780443 - Apartado 191 - 39080 - Santander, Cantabria (Spain)  
[www.fonestar.com](http://www.fonestar.com)