



# FDM-1060, FDM-1060-4

## DYNAMIC MICROPHONE



FDM-1060



FDM-1060-4

### DESCRIPTION

Dynamic hand-held microphones for general and professional use.

### SPECIFICATIONS

	FDM-1060	FDM-1060-4
<b>CAPSULE</b>	Unidirectional dynamic	
<b>RESPONSE</b>	50-15 000 Hz	
<b>SENSITIVITY</b>	-56 dB (V/Pa) at 1 kHz	
<b>IMPEDANCE</b>	600 Ω	
<b>POWER SWITCH</b>	On/off	
<b>BODY</b>	Cast-iron, black	
<b>CABLE</b>	3 m with female PF-4 connectors and mono 6.3 mm plug. Unbalanced line	4 m extendable with female PF-4 and DIN-5 connectors for contact closure through switch Unbalanced line
<b>ACCESSORIES</b>	Microphone stand and protective case	Protective case

### FREQUENCY RESPONSE

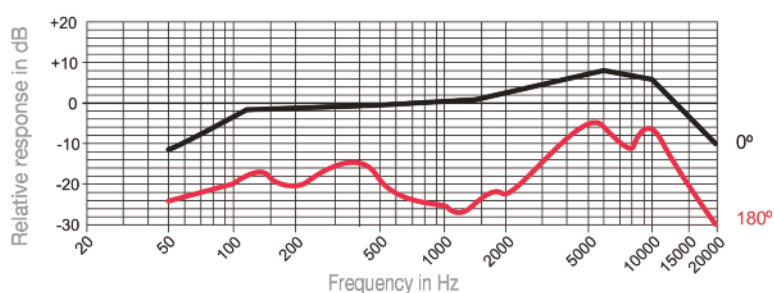

### POLAR DIAGRAM

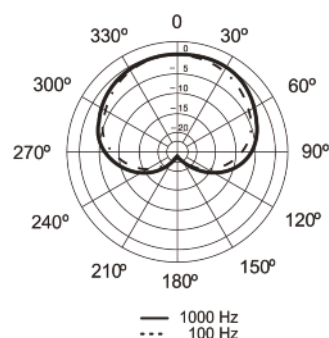

### WARRANTY

This product has been tested and has passed the corresponding quality control prior to being put on the market.

**FONESTAR** guarantees the suitability of the product for its specified use during a period of 2 years from the delivery date and commits itself to repair or substitute the goods as expressed in the Spanish law 'La Ley General para la Defensa de los Consumidores y Usuarios, Real Decreto Legislativo 1/2007 16 Noviembre.

The lack of conformity in the first six months after purchase, due to a manufacturing defect, will be rectified with no more than showing the proof of purchase. After six months **FONESTAR** reserves the right to demand proof of the product being sold with that problem.

This warranty does not include damage produced by: inappropriate use or negligence, accidents, worn out parts due to use, breakages, burns, spill liquids or other substances, excessive humidity, battery deterioration and internal manipulation of the device, the software or its components by unauthorized persons, and in general any use that is unrelated to the nature and purpose of the product. If any service is needed during the warranty period because of lack of conformity, please contact the business or distributor where the product was purchased in no more than 2 months after being conscious of the problem. It is only necessary to contact **FONESTAR** if it is impossible or imposes an undue burden for them to solve it.

To benefit from this warranty it is necessary to show the proof of purchase with the date clearly visible, with no corrections or crossing out.

This document adds information, and never decreases the consumers' rights, which in all cases are protected by the Spanish law 'La Ley General para la Defensa de los Consumidores y Usuarios, Real Decreto Legislativo 1/2007 16 Noviembre'.



**FONESTAR** is a member of ECOEMBALAJES ESPAÑA, S.A. "ECOEMBES", with number 03497 and all our products carry the symbol, backed by our membership and subscription to the above mentioned organization with the recycling and subsequent management of our packaging.

**FONESTAR** is registered in the RAEE (Registro de Aparatos Eléctricos y Electrónicos) in a special section REI (Registro de establecimientos Industriales), with the entry number 001851.

FONESTAR S.A. - NIF A28780443 - Apartado 191 - 39080 - Santander, Cantabria, (Spain)

[www.fonestar.com](http://www.fonestar.com)