

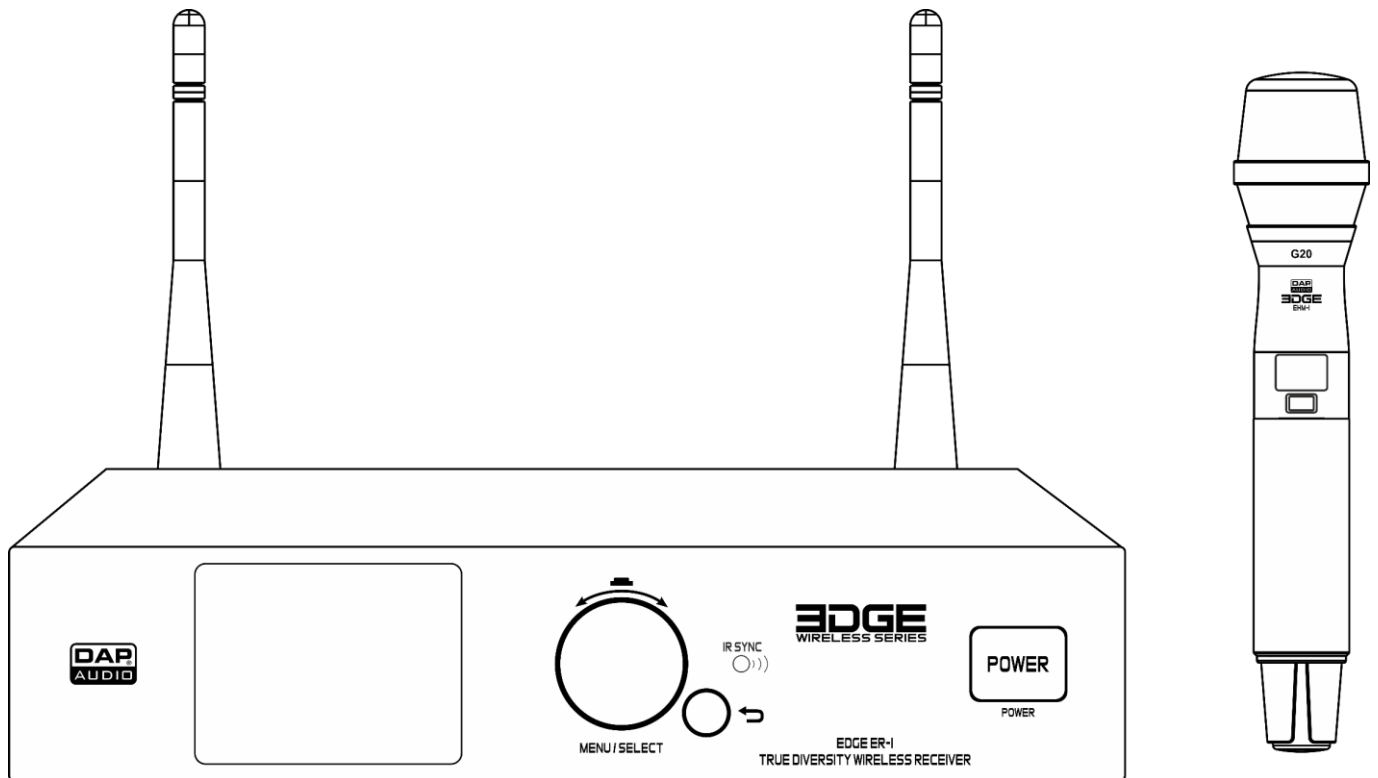

# MANUAL



ENGLISH

## EDGE EHS-1

## V2

Order code: D1475B

**Table of contents**

**Warning** .....2  
 Safety Instructions.....2  
 Operating Determinations.....4  
 Connection with the Mains .....4  
 Return Procedure .....5  
 Claims .....5

**Description of the Device** .....6  
 Overview.....7  
 Transmitter .....7  
 Receiver (Front) .....7  
 Receiver (Back).....8

**Installation**.....8  
 Mounting – Single Receiver .....8  
 Mounting – Multiple Receivers.....9  
 Setup Examples .....10  
 4 x EDGE EHS-1 .....10  
 8 x EDGE EHS-1 .....11

**Setup and Operation** .....12  
 Control Panel .....13  
 Inserting the Batteries .....13  
 Compensation of Interference with Balanced Connections.....14  
 Main Menu Options .....14  
 1. Group .....15  
 2. Channel.....15  
 3. Freq.....16  
 4. Scan.....17  
 5. Sync .....17  
 6. Lock .....18  
 7. Tx Gain .....18  
 8. Rx Gain.....18  
 9. Low Cut.....19  
 10. Squelch.....19  
 11. Tone Key .....19  
 12. Color.....20  
 13. Name .....20  
 14. Ant Dc .....21  
 Transmitter.....22  
 Mute .....22  
 Main Menu Options .....22  
 1. Group .....23  
 2. Channel.....23  
 3. Freq.....23  
 4. Gain.....24  
 5. RF Power .....24  
 6. Lock .....25

**Connection Cables**.....26  
**Maintenance** .....27  
**Troubleshooting** .....27  
**Approval** .....28  
**Product Specifications**.....29  
**Dimensions**.....30

## Warning



**For your own safety, please read this user manual carefully  
before your initial start-up!**



### Unpacking Instructions

Immediately upon receiving this product, carefully unpack the carton and check the contents to ensure that all parts are present, and have been received in good condition. Notify the dealer immediately and retain packing material for inspection if any parts appear damaged from shipping or the carton itself shows signs of mishandling. Save the carton and all packing materials. In the event that a device must be returned to the factory, it is important that the device is returned in the original factory box and packing.

### Your shipment includes:

- DAP Audio EDGE EHS-1 (receiver + transmitter)
- DC power adapter
- 1 x long mounting bracket
- 1 x short mounting bracket
- 1 x mounting plate
- 1 x mono jack cable (1 m)
- 1 x leather bag
- Color cap stickers
- User manual

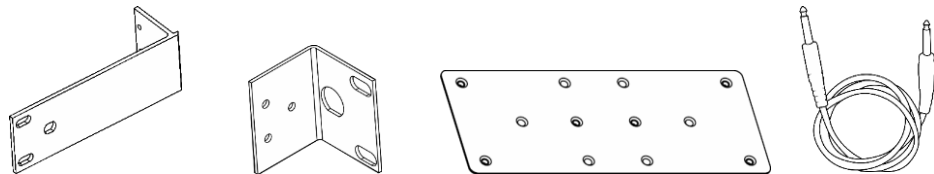
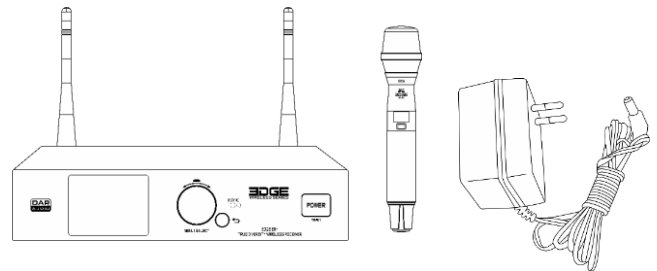

### CAUTION!

**Keep this device away from rain and moisture!  
Unplug mains lead before opening the housing!**



### Safety Instructions

Every person involved with the installation, operation and maintenance of this system has to:

- be qualified
- follow the instructions of this manual.



**CAUTION! Be careful with your operations.  
With a dangerous voltage you can suffer  
a dangerous electric shock when touching the wires!**



Before the initial start-up, please make sure that there is no damage caused by transportation. Should there be any, consult your dealer and do not use the system.

To maintain perfect condition and to ensure a safe operation, it is absolutely necessary for the user to follow the safety instructions and warning notes written in this manual.

Please consider that damages caused by manual modifications to the system are not subject to warranty.

This system contains no user-serviceable parts. Refer servicing to qualified technicians only.

**IMPORTANT:**

The manufacturer will not accept liability for any resulting damages caused by the non-observance of this manual or any unauthorized modification to the device.

**Before using the device, check the regulations regarding the frequency allocation in your country or region.**

- Never use the device during thunderstorms, unplug the device immediately.
- Never leave various parts of the packaging (plastic bags, polystyrene foam, nails, etc.) within children's reach, as they are potential sources of danger.
- Never remove warning or informative labels from the unit.
- Never leave any cables lying around.
- Do not open the device and do not modify the device.
- Do not switch the system on and off in short intervals, as this would reduce the system's life.
- Only use device indoors, avoid contact with water or other liquids.
- Avoid flames and do not put close to flammable liquids or gases.
- Always disconnect power from the mains, when device is not used or before cleaning! Only handle the power cord by the plug. Never pull out the plug by tugging the power cord.
- Use only the supplied DC power adapter.
- Make sure that the power cord is never crimped or damaged. Check the system and the power cord from time to time.
- Make sure that the available voltage is not higher than stated on the rear panel.
- Make sure you do not use the wrong kind of cables or defective cables.
- If system is dropped or struck, disconnect the power supply immediately. Have a qualified engineer inspect for safety before operating.
- If the system has been exposed to drastic temperature fluctuation (e.g. after transportation), do not switch it on immediately. The arising condensation water might damage your system. Leave the system switched off until it has reached room temperature.
- Do not put your equipment next to TV, radio, etc., because of interference or distortion.
- Prevent distortion! Make sure that all components connected to the device have sufficient power ratings. Otherwise, distortion will be generated because the components are operated at their limits.
- If your DAP Audio device fails to work properly, discontinue use immediately. Pack the unit securely (preferably in the original packing material), and return it to your DAP Audio dealer for service.
- Please read this manual carefully and keep it for future reference.
- Repairs, servicing and electric connection must be carried out by a qualified technician.
- WARRANTY: Till one year after date of purchase.

**Operating Determinations**

- This device is not designed for permanent operation. Consistent operation breaks will ensure that the device will serve you for a long time without defects.
- The maximum ambient temperature  $t_a = 40\text{ °C}$  must never be exceeded.
- The relative humidity must not exceed 50 % with an ambient temperature of 40 °C.
- If this device is operated in any other way, than the one described in this manual, the product may suffer damages and the warranty becomes void.
- Any other operation may lead to dangers like short-circuit, burns, electric shock, crash, etc.

*You endanger your own safety and the safety of others!*

**Connection with the Mains**

Connect the receiver to the mains with the supplied AC power adapter.  
Always pay attention, that the right color cable is connected to the right place.

<b>International</b>	<b>EU Cable</b>	<b>UK Cable</b>	<b>US Cable</b>	<b>Pin</b>
L	BROWN	RED	YELLOW/COPPER	PHASE
N	BLUE	BLACK	SILVER	NEUTRAL
	YELLOW/GREEN	GREEN	GREEN	PROTECTIVE GROUND

*Make sure that the device is always connected properly to the earth!*

*Improper installation can cause serious damage to people and property!*



### **Return Procedure**

Returned merchandise must be sent prepaid and in the original packing, call tags will not be issued. Package must be clearly labeled with a Return Authorization Number (RMA number). Products returned without an RMA number will be refused. Highlite will not accept the returned goods or any responsibility. Call Highlite 0031-455667723 or mail [offersales@highlite.com](mailto:offersales@highlite.com) and request an RMA prior to shipping the fixture. Be prepared to provide the model number, serial number and a brief description of the cause for the return. Be sure to properly pack fixture, any shipping damage resulting from inadequate packaging is the customer's responsibility. Highlite reserves the right to use its own discretion to repair or replace product(s). As a suggestion, proper UPS packing or double-boxing is always a safe method to use.

**Note: If you are given an RMA number, please include the following information on a piece of paper inside the box:**

- 01) Your name
- 02) Your address
- 03) Your phone number
- 04) A brief description of the symptoms

### **Claims**

The client has the obligation to check the delivered goods immediately upon delivery for any shortcomings and/or visible defects, or perform this check after our announcement that the goods are at their disposal. Damage incurred in shipping is the responsibility of the shipper; therefore the damage must be reported to the carrier upon receipt of merchandise.

It is the customer's responsibility to notify and submit claims with the shipper in the event that a fixture is damaged due to shipping. Transportation damage has to be reported to us within one day after receipt of the delivery.

Any return shipment has to be made post-paid at all times. Return shipments must be accompanied with a letter defining the reason for return shipment. Non-prepaid return shipments will be refused, unless otherwise agreed in writing.

Complaints against us must be made known in writing or by fax within 10 working days after receipt of the invoice. After this period complaints will not be handled anymore.

Complaints will only then be considered if the client has so far complied with all parts of the agreement, regardless of the agreement of which the obligation is resulting.

## Description of the Device

The EDGE EHS-1 is a wireless handheld system. The set consists of a handheld transmitter and a receiver. The EDGE is suitable for voice transmission. The transmitter is powered by two AA 1,5 V batteries.

### Features

#### Receiver

- Modulation: FM
- Power supply: DC 12–15 V, 300 mA
- Frequency range: 606–668 MHz
- Frequency response: 75 Hz–18 kHz
- Sensitivity: -100 dBm/30 dB sinad
- Distortion: <1%(AF1 kHz, RF46 dBu)
- Max SPL: 128 dB SPL
- RF stability:  $\leq \pm 15$  ppm
- Frequency deviation:  $\pm 75$  kHz
- Spurious rejection: >50 dB
- SNR: >100 dBA
- Transmission latency: 0 ms
- Audio outputs: 3-pin XLR OUT balanced, mono 1/4" jack unbalanced
- Indicators: A/B antenna, AF signal
- Pilot frequency: 32768 kHz
- Output signal sensitivity adjustable range: 48 dB, Adopt 6 dB step for adjustment
- Dimensions: 205 x 170 x 263 mm (LxWxH)
- Weight: 1,24 kg

#### Transmitter

- Type microphone: Dynamic
- Output gain range: 30 dB
- RF output: 10 mW\*/20 mW/30 mW
- Power supply: 2 x AA 1,5 V batteries (not included)
- Dimensions: Ø51 mm x 255 mm (WxH)
- Weight: 0,4 kg

\* - The maximum allowed RF output is 10 mW. The use of outputs stronger than 10 mW must be permitted by the local authorities.

#### Optional accessories:

[D1317](#) – Microphone windscreen set

[D1320](#) – Microphone windscreen set, black

[98043](#) – Procell alkaline battery (AA LR6 1,5 V)

Overview

Transmitter

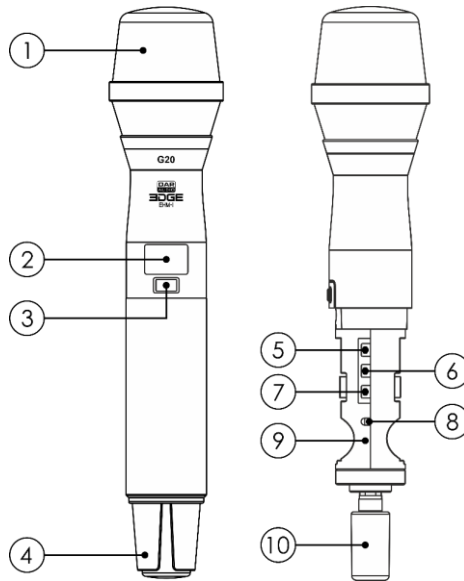

Fig. 01

- 01) Microphone head
- 02) OLED display
- 03) Power button
  - While in main menu, press the button to confirm your choice and return to the start screen.
  - Press and hold down this button for 3 seconds to switch the transmitter ON/OFF.
- 04) Battery cover
- 05) UP button
- 06) DOWN button
- 07) SET button
- 08) IR sensor
- 09) Battery housing (2 x AA)
- 10) Transmitter antenna

Receiver (Front)

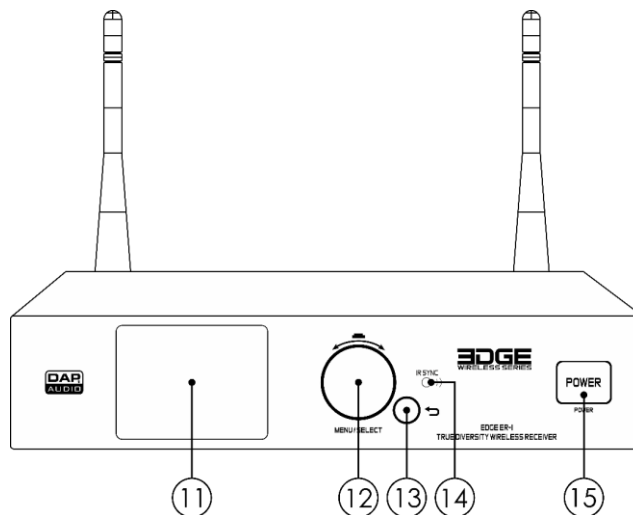

Fig. 02

- 11) LCD display
- 12) Control
  - Turn/press this control to select, adjust and confirm the main menu options.
- 13) Return button
- 14) IR sensor
- 15) Power button
  - Press and hold down this button for 2 seconds to switch the device on/off.



Receiver (Back)

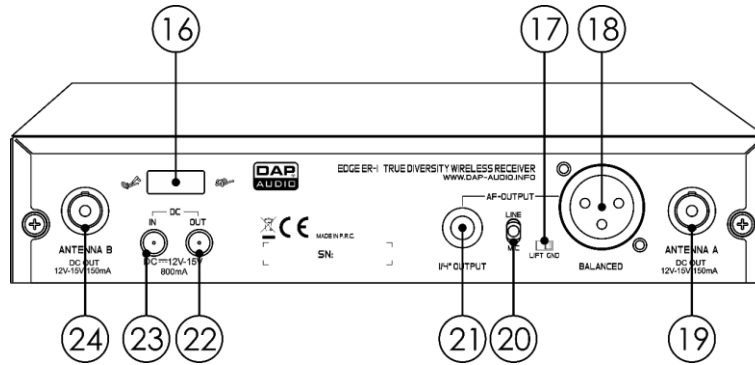

Fig. 03

- 16) Power cable safety eye
- 17) Ground/lift switch
- 18) 3-pin XLR AF balanced OUT
- 19) BNC antenna A connector
- 20) Mic/line switch
- 21) AF connector OUT (6,3 mm jack)
- 22) 12–15 V DC power connector OUT
- 23) 12–15 V DC power connector IN
- 24) BNC antenna B connector

Installation

Remove all packing materials from the EDGE EHS-1. Check if all foam and plastic padding is removed. Secure the equipment into a 19" rack if preferred. Connect the receiver to a power outlet with the supplied DC power adaptor. Connect all cables. Insert the batteries into the transmitter.

**Always disconnect from electric mains power supply before cleaning or servicing.**  
**Damages caused by non-observance are not subject to warranty.**

Mounting – Single Receiver

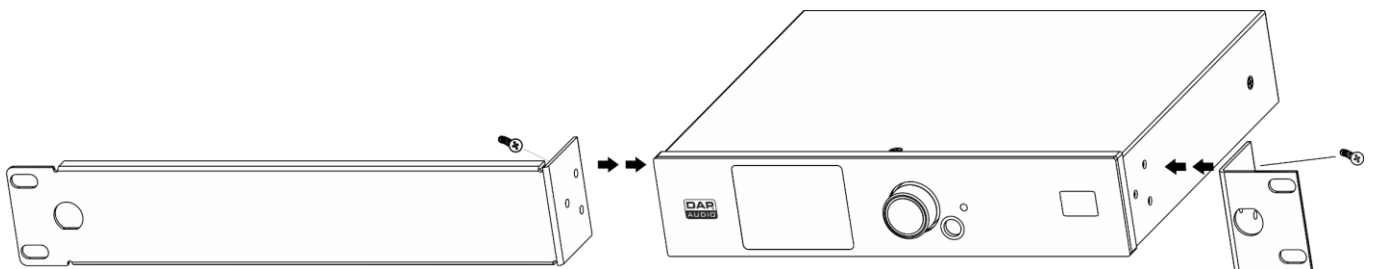

Fig. 04

### Mounting – Multiple Receivers

Step 1

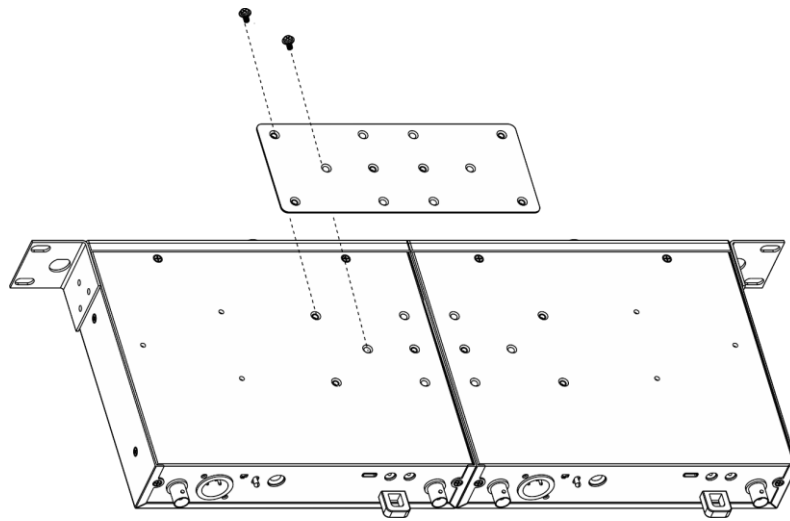

Fig. 05

Step 2

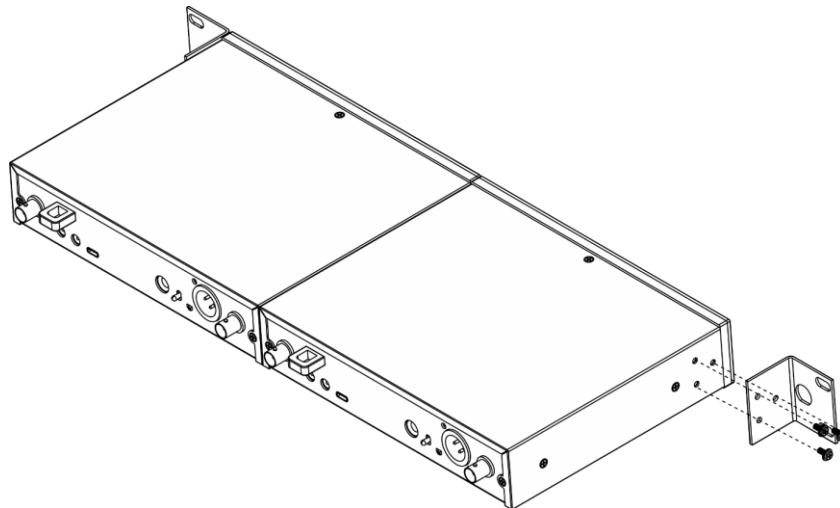

Fig. 06

Step 3

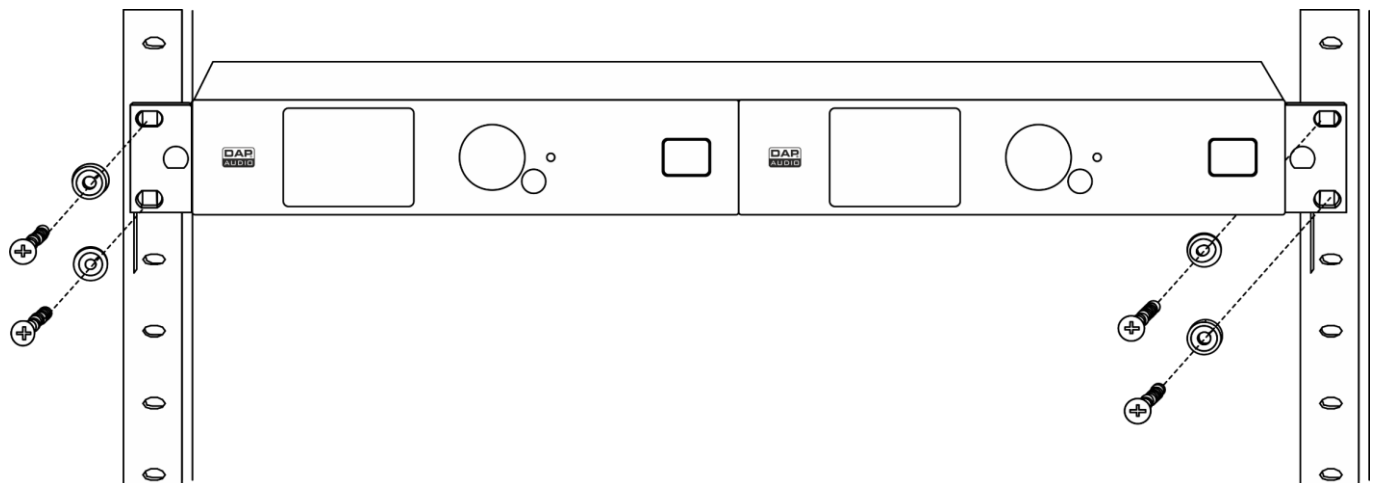

Fig. 07

Setup Examples

4 x EDGE EHS-1

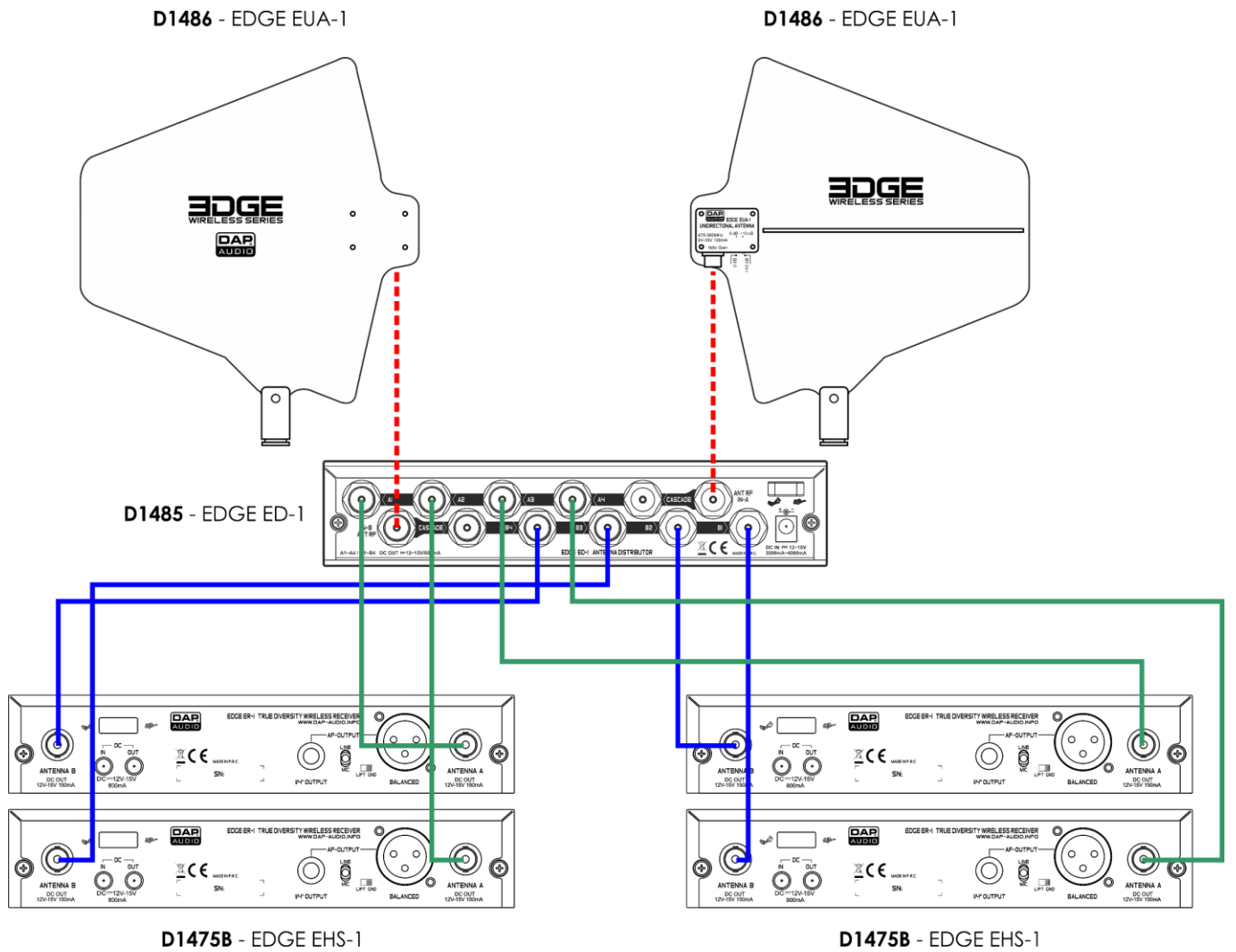
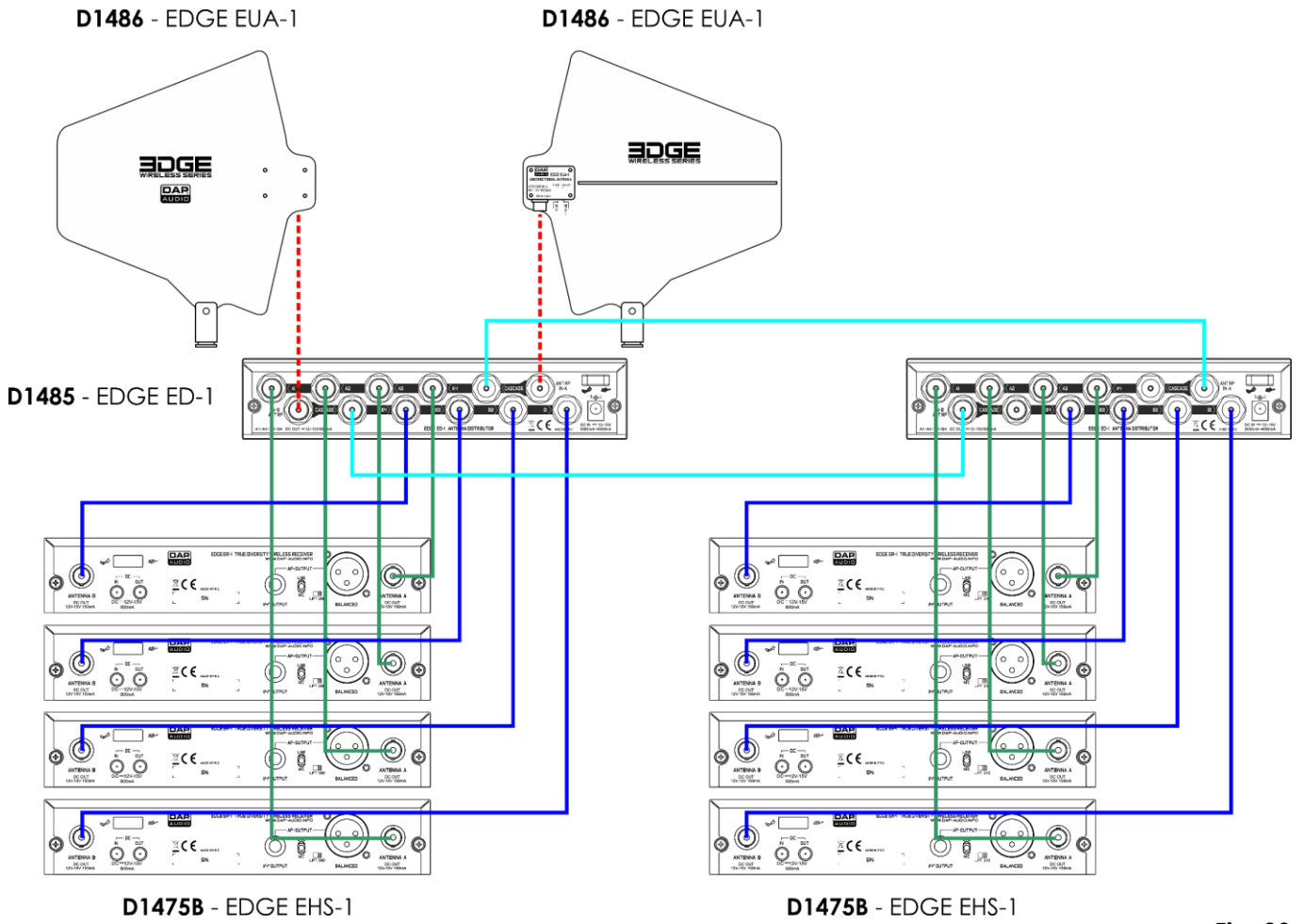

Fig. 08

**8 x EDGE EHS-1**



**Fig. 09**

## Setup and Operation

Follow the directions below, as they pertain to your preferred operation mode. **Before using the device, check the regulations regarding the frequency allocation in your country or region.** Before plugging the unit in, always make sure that the power supply matches the product specification voltage.

- 01) Connect the supplied power adapter to the **DC power connector (23)** on the rear of the receiver.
- 02) Plug the power adapter into a power outlet. Use only the supplied power adapter to connect the device.
- 03) Press and hold down the **power button (15)** for 2 seconds to turn the device on.
- 04) Point the **antennas (19/24)** away from each other in a 45° position as shown in Fig. 10. Avoid placing the receiver antennas near metal surfaces or other obstructions. Make sure the antennas do not cross if stacking or rack-mounting receivers in a multiple-system setup.

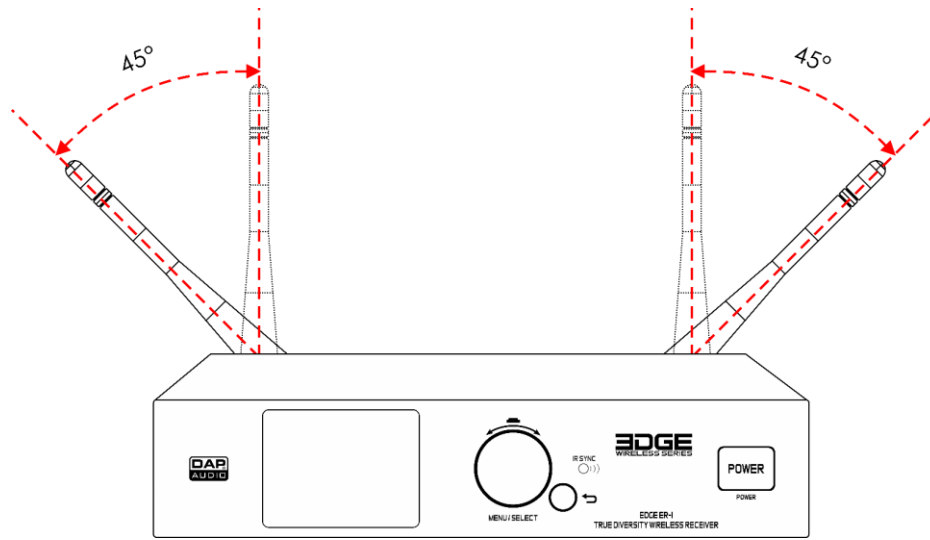
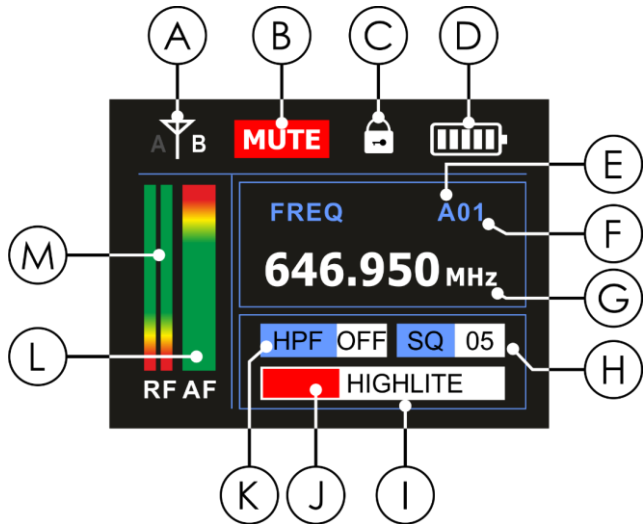

Fig. 10

- 05) To connect the receiver to an amplifier either use an XLR to XLR cable, to connect via the receiver's **3-pin XLR connector OUT (18)**, or a 1/4" mono jack cable via the **AF jack connector OUT (21)**.
- 06) Insert the batteries into the transmitter. See chapter: **Inserting the Batteries**, page 13.
- 07) Press and hold down the **power switch (03)** for 3 seconds to turn the transmitter on.
- 08) Pair the transmitter with the receiver. See chapters **4. Scan** and **5. Sync**, page 17.
- 09) During use of the transmitter, the AF signal indicators will show the intensity of the incoming audio signal.
- 10) Adjust the volume on the receiver and on the connected mixer or amplifier.
- 11) Mute the transmitter before turning it off, to prevent the occurrence of a popping sound.
- 12) Make sure you can always see a receiver antenna from the transmitter position. Keep the distance from the transmitter to the receiver antenna as short as possible.
- 13) Perform a walk-through before performance or presentation to identify any dead spots. In case of dead spots, adjust the location of the receiver. Should this not be sufficient, mark the dead spots in order to avoid them.

Control Panel



- A) Antenna signal
- B) AF signal mute
- C) Receiver lock
- D) Transmitter battery status
- E) Group (A-J)
- F) Channel (1-14)
- G) Receiver frequency
- H) Squelch
- I) Device name
- J) User color
- K) High-pass filter status
- L) AF signal strength
- M) Wireless signal strength

Fig. 11

Inserting the Batteries

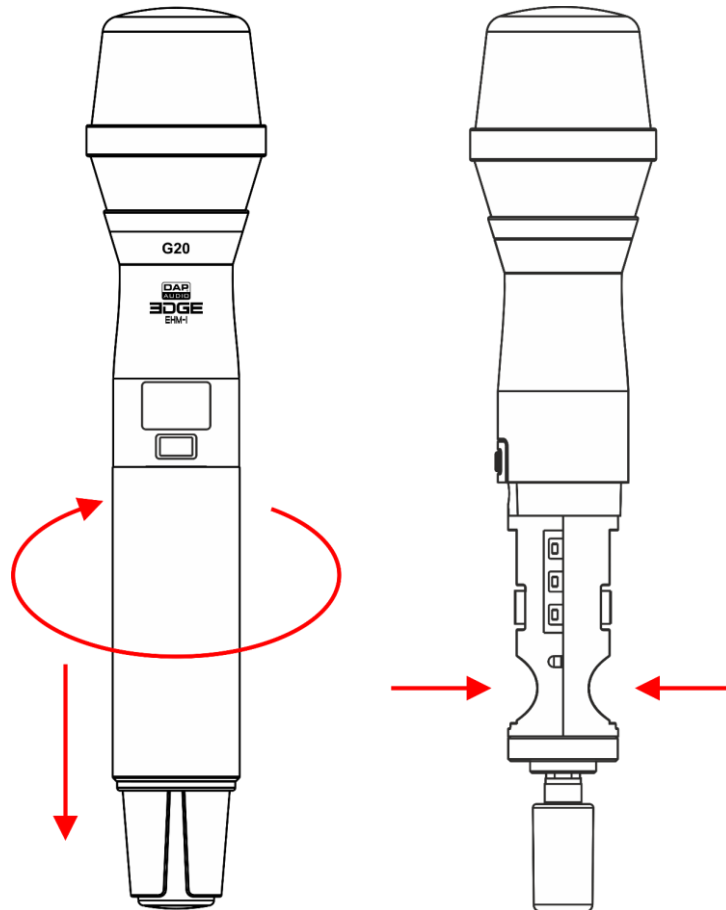
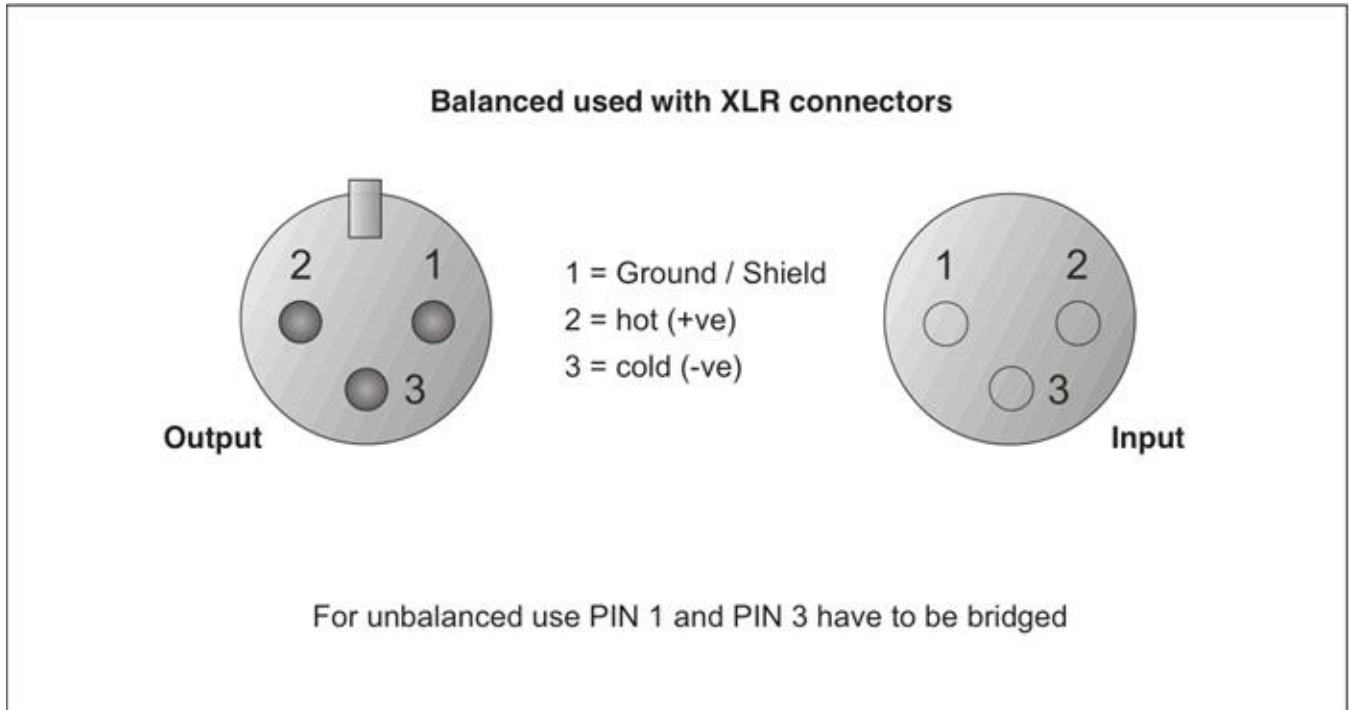

Fig. 12

- 01) Turn the **battery cover (04)** counter-clockwise to loosen it.
- 02) Remove the battery cover.
- 03) Insert the batteries into the battery housing. The transmitter operates with two AA 1,5 V batteries. While inserting the batteries, mind the (+) and (-) symbols on the batteries and the housing.
- 04) Replace the **battery cover (04)** and turn it clockwise to fasten it. Do not overtighten to prevent cross-threading.

## Compensation of Interference with Balanced Connections



## Main Menu Options

01) Upon start-up, the display will show the DAP Audio logo. After 2 seconds, the display will show the current device status.

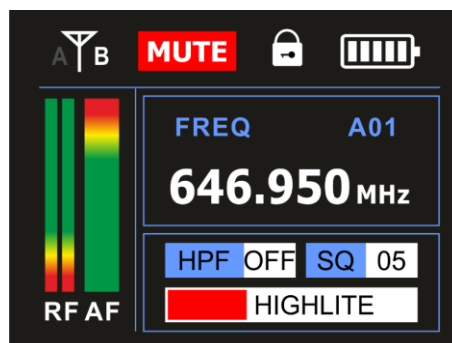

02) Press the **control (12)** to open the main menu. The display will show:

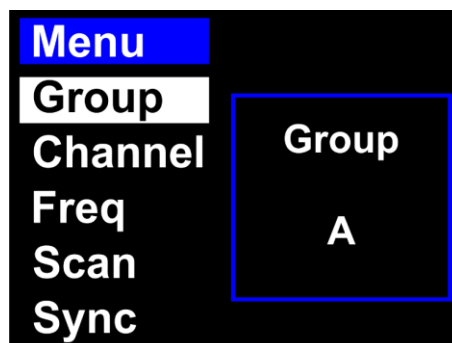

03) Turn the **control (12)** to toggle through the following 14 menus:

- GROUP
- CHANNEL
- FREQ
- SCAN

- SYNC
- LOCK
- TX GAIN
- RX GAIN
- LOW CUT
- SQUELCH
- TONE KEY
- COLOR
- NAME
- ANT DC

04) Press the **control (12)** to open the desired menu.

### 1. Group

In this menu you can set the desired group. Each group (A–J) has a unique set of channels with 14 fixed frequencies per channel. See the table on page 16.

01) Turn the **control (12)** until the display shows:

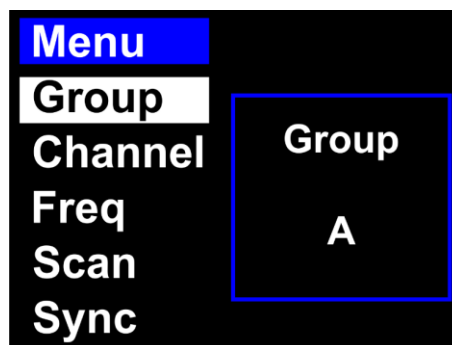

02) Press the **control (12)** to edit.

03) Turn the **control (12)** to select the desired group. The adjustment range is A–J.

04) Press the **control (12)** to save changes.

### 2. Channel

In this menu you can set the desired channel. Each channel (1–14) has a unique fixed frequency. See the table on page 16.

01) Turn the **control (12)** until the display shows:

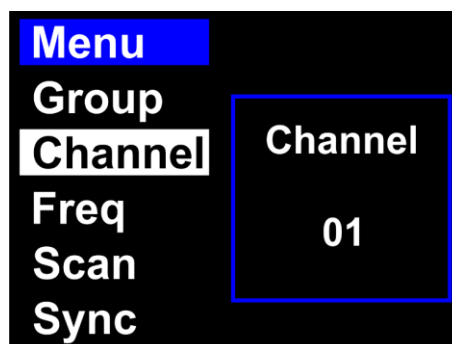

02) Press the **control (12)** to edit.

03) Turn the **control (12)** to select the desired channel. The adjustment range is 1–14.

04) Press the **control (12)** to save changes.



A	B	C	D	E
[1]:606.000MHz	[1]:606.200MHz	[1]:606.225MHz	[1]:606.300MHz	[1]:606.425MHz
[2]:608.025MHz	[2]:608.225MHz	[2]:607.250MHz	[2]:607.325MHz	[2]:607.450MHz
[3]:610.325MHz	[3]:610.525MHz	[3]:608.475MHz	[3]:608.550MHz	[3]:608.675MHz
[4]:612.900MHz	[4]:613.100MHz	[4]:609.925MHz	[4]:610.000MHz	[4]:610.125MHz
[5]:615.750MHz	[5]:615.950MHz	[5]:611.600MHz	[5]:611.675MHz	[5]:611.800MHz
[6]:618.875MHz	[6]:619.075MHz	[6]:614.050MHz	[6]:614.125MHz	[6]:614.250MHz
[7]:622.275MHz	[7]:622.475MHz	[7]:617.375MHz	[7]:617.450MHz	[7]:617.575MHz
[8]:626.050MHz	[8]:626.250MHz	[8]:620.275MHz	[8]:620.350MHz	[8]:620.475MHz
[9]:631.200MHz	[9]:631.400MHz	[9]:622.175MHz	[9]:622.250MHz	[9]:622.375MHz
[10]:639.475MHz	[10]:639.675MHz	[10]:626.750MHz	[10]:626.825MHz	[10]:626.950MHz
[11]:645.175MHz	[11]:645.375MHz	[11]:631.775MHz	[11]:631.850MHz	[11]:631.975MHz
[12]:653.175MHz	[12]:653.375MHz	[12]:638.775MHz	[12]:638.850MHz	[12]:638.975MHz
[13]:663.750MHz	[13]:663.950MHz	[13]:653.400MHz	[13]:653.475MHz	[13]:653.600MHz
[14]:667.800MHz	[14]:668.000MHz	[14]:661.750MHz	[14]:661.825MHz	[14]:661.950MHz

F	G	H	I	J
[1]:606.950MHz	[1]:607.000MHz	[1]:607.200MHz	[1]:607.225MHz	[1]:607.300MHz
[2]:607.975MHz	[2]:608.225MHz	[2]:608.300MHz	[2]:608.250MHz	[2]:608.625MHz
[3]:609.200MHz	[3]:609.250MHz	[3]:609.450MHz	[3]:609.700MHz	[3]:610.175MHz
[4]:610.650MHz	[4]:610.700MHz	[4]:610.900MHz	[4]:611.375MHz	[4]:611.950MHz
[5]:612.325MHz	[5]:612.375MHz	[5]:612.575MHz	[5]:614.075MHz	[5]:613.925MHz
[6]:614.775MHz	[6]:614.825MHz	[6]:615.025MHz	[6]:615.975MHz	[6]:617.000MHz
[7]:618.100MHz	[7]:618.150MHz	[7]:618.350MHz	[7]:621.125MHz	[7]:621.200MHz
[8]:621.000MHz	[8]:621.050MHz	[8]:621.250MHz	[8]:624.475MHz	[8]:623.400MHz
[9]:622.900MHz	[9]:622.950MHz	[9]:623.150MHz	[9]:628.400MHz	[9]:631.350MHz
[10]:627.475MHz	[10]:627.525MHz	[10]:627.725MHz	[10]:639.025MHz	[10]:633.975MHz
[11]:632.500MHz	[11]:632.550MHz	[11]:632.750MHz	[11]:643.825MHz	[11]:639.950MHz
[12]:639.500MHz	[12]:639.550MHz	[12]:639.750MHz	[12]:649.875MHz	[12]:646.975MHz
[13]:654.125MHz	[13]:654.175MHz	[13]:654.375MHz	[13]:655.475MHz	[13]:660.400MHz
[14]:662.475MHz	[14]:662.525MHz	[14]:662.725MHz	[14]:667.350MHz	[14]:664.800MHz

### 3. Freq

In this menu you can manually set the desired frequency.

01) Turn the **control (12)** until the display shows:

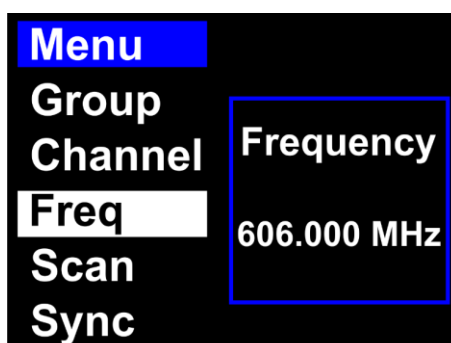

02) Press the **control (12)** to edit.

03) Turn the **control (12)** to select the desired frequency. The adjustment range is between 606–668 MHz.

04) Press the **control (12)** to save changes.

#### 4. Scan

In this menu you can automatically scan the entire frequency range, in order to find and choose the unused frequency. By doing so, you can avoid signal distortion.

01) Turn the **control (12)** until the display shows:

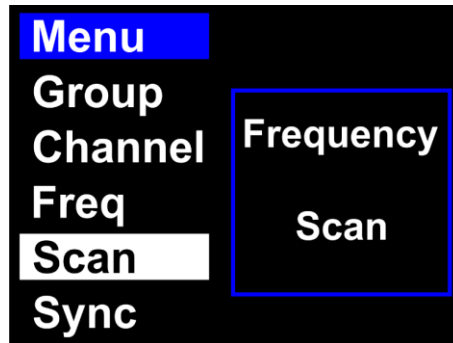

02) Press the **control (12)** to enter. The display will show:

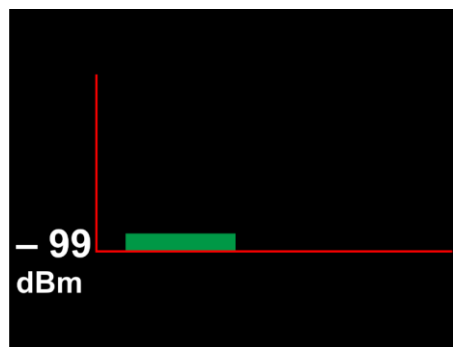

03) The device will now automatically scan the entire frequency range (606–668 MHz). This process may take up to 2 minutes.

04) Once the scanning is finished, turn the **control (12)** to select the desired frequency. Choose the least used frequency in order to avoid signal distortion.

05) Press the **control (12)** to confirm.

#### 5. Sync

In this menu you can pair the receiver with the transmitter.

01) Turn the **control (12)** until the display shows:

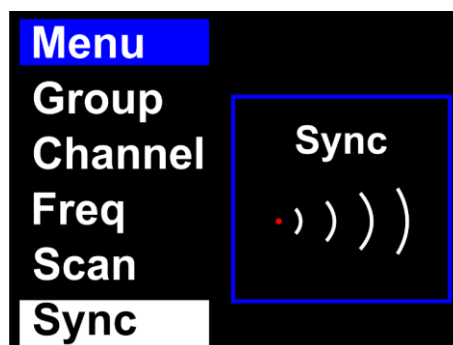

02) Turn the **battery cover (04)** of the transmitter counter-clockwise to loosen it.

03) Remove the battery cover.

04) Press and hold down the **power button (03)** on the transmitter for 3 seconds to switch it ON.

05) Place the transmitter close to the receiver's display (10–20 cm). Make sure that you point the **IR sensor (08)** on the transmitter at the **IR sensor (14)** on the receiver.

06) Press the **control (12)** to pair the devices. The **IR sensor (14)** on the receiver will blink several times. The devices are now paired and ready for use.

07) Replace the **battery cover (04)** and turn it clockwise to fasten it. Do not overtighten to prevent cross-threading.

## 6. Lock

In this menu you can lock the receiver's display.

01) Turn the **control (12)** until the display shows:

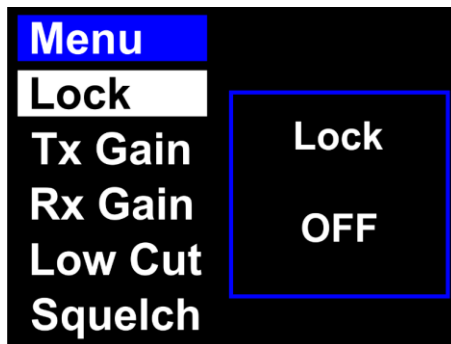

02) Press the **control (12)** to edit.

03) Turn the **control (12)** to select ON or OFF.

04) Press the **control (12)** to confirm.

05) If you have chosen ON, the display will be locked.

06) In order to unlock the display, press and hold down the **control (12)** for 4 seconds, until the receiver lock symbol disappears (see C, Fig. 11, page 13).

Note: The receiver will not lock automatically. It can be locked only manually.

## 7. Tx Gain

In this menu you can set the audio gain of the transmitter (input sensitivity).

01) Turn the **control (12)** until the display shows:

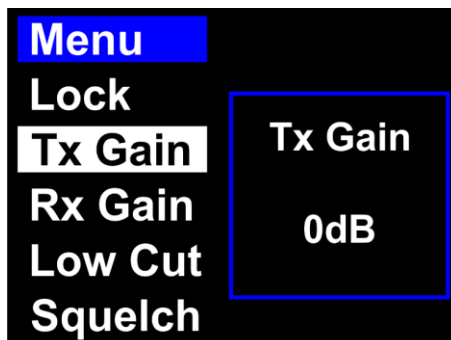

02) Press the **control (12)** to edit.

03) Turn the **control (12)** to set the desired gain. The adjustment range is from -32 dB to +4 dB.

04) Press the **control (12)** to save changes.

## 8. Rx Gain

In this menu you can set the output gain of the receiver.

01) Turn the **control (12)** until the display shows:

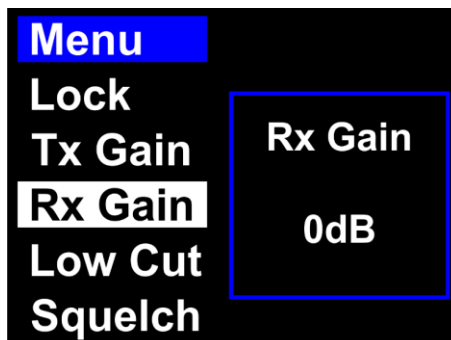

02) Press the **control (12)** to edit.

03) Turn the **control (12)** to set the desired gain. The adjustment range is from -32 dB to +4 dB.

04) Press the **control (12)** to save changes.

### 9. Low Cut

In this menu you can set the high-pass filter. The high-pass filter removes low frequency signals picked up by the transmitter.

01) Turn the **control (12)** until the display shows:

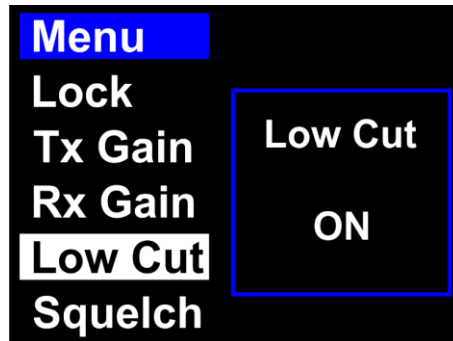

02) Press the **control (12)** to edit.

03) Turn the **control (12)** to select ON or OFF.

04) Press the **control (12)** to confirm.

### 10. Squelch

In this menu you can set the squelch threshold. It eliminates the noise resulting from momentary spikes in the output when turning the transmitter off. When too high in poor reception areas, it may compromise the reception range. When too low, the noise may damage your hearing and/or the speakers.

01) Turn the **control (12)** until the display shows:

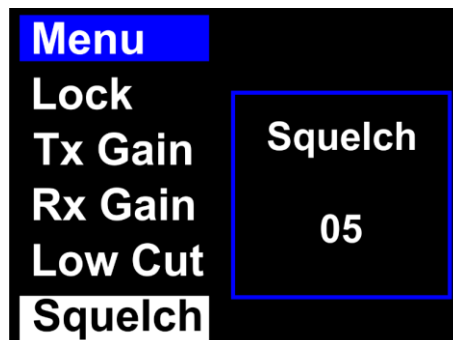

02) Press the **control (12)** to edit.

03) Turn the **control (12)** to set the value. The adjustment range is 1–10.

04) Press the **control (12)** to save changes.

### 11. Tone Key

In this menu you can set the tone key, by means of which the receiver can identify the presence of the transmitter. The tone key also provides the battery status indication on the receiver.

01) Turn the **control (12)** until the display shows:

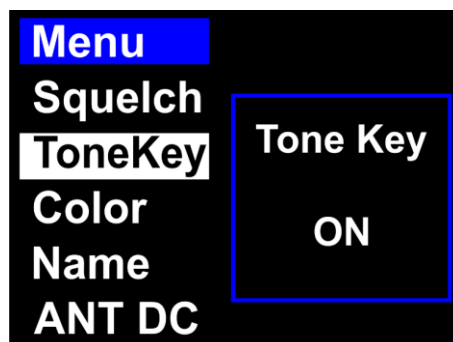

02) Press the **control (12)** to edit.

03) Turn the **control (12)** to select ON or OFF.

04) Press the **control (12)** to confirm.

## 12. Color

In this menu you can set the receiver's color. It is useful when working with multiple receivers and transmitters.

01) Turn the **control (12)** until the display shows:

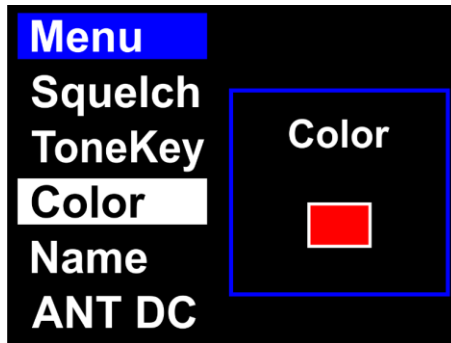

02) Press the **control (12)** to edit.

03) Turn the **control (12)** to select one of the 8 colors (red, yellow, green, blue, orange, brown, white, black).

04) Press the **control (12)** to confirm.

## 13. Name

In this menu you can set the receiver's name. A name can consist of up to 8 characters.

01) Turn the **control (12)** until the display shows:

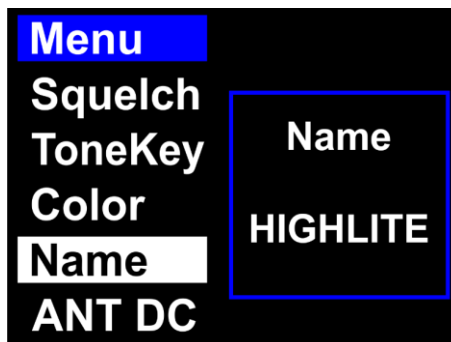

02) Press the **control (12)** to edit.

03) Turn the **control (12)** to choose the desired symbol for the first character.

04) Press the **control (12)** to confirm your choice and proceed to the following character. The currently selected character will be highlighted.

05) Repeat steps 3–4 to edit the remaining characters.

**14. Ant Dc**

In this menu you can set the antenna input/output power supply.

01) Turn the **control (12)** until the display shows:

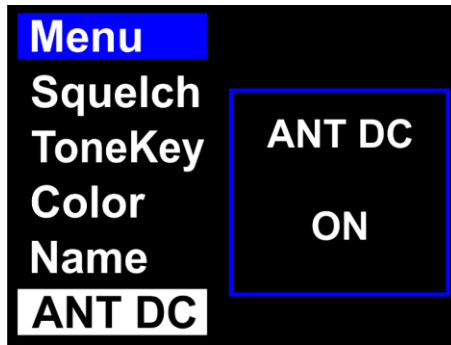

02) Press the **control (12)** to edit.

03) Turn the **control (12)** to select ON or OFF.

04) Press the **control (12)** to confirm.

- If the input power comes from the power adapter: the "ANT DC: On" will power the active antenna via the **BNC antenna connectors (19/24)**.
- If the input power comes from the antenna distributor: the "ANT DC: On" will power the receiver.

Note: When using the antenna distributor together with the power adapter, ANT DC must be set to "Off"

### Transmitter

- 01) Turn the **battery cover (04)** of the transmitter counter-clockwise to loosen it.
- 02) Remove the battery cover.
- 03) Press and hold down the **power button (03)** for 3 seconds to switch the transmitter ON/OFF.
- 04) Upon start-up, the display will show the following splash screen:



### Mute

- 01) Press the **power button (03)** once, to mute the transmitter.
- 02) Press the **power button (03)** again to deactivate mute.

### Main Menu Options

- 01) Press the **SET button (07)** to open the main menu. The display will show:

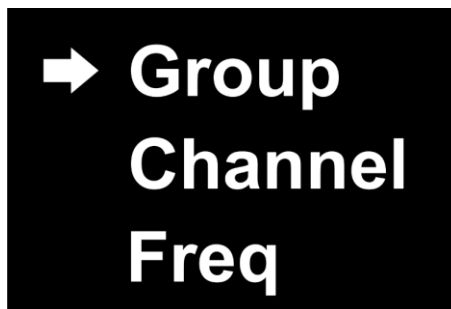

- 02) Press the **UP/DOWN buttons (05/06)** to toggle through the following 6 menus:
  - GROUP
  - CHANNEL
  - FREQ
  - GAIN
  - RF POWER
  - LOCK
- 03) Press the **SET button (07)** to open the desired menu.

### 1. Group

In this menu you can set the desired group.

01) Press the **UP/DOWN buttons (05/06)** until the display shows:

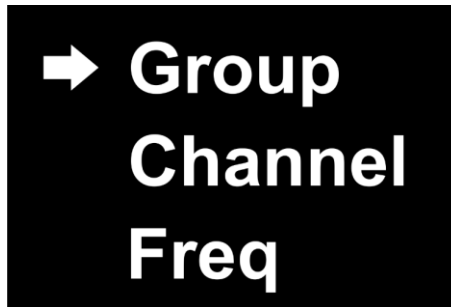

02) Press the **SET button (07)** to edit.

03) Press the **UP/DOWN buttons (05/06)** to select the desired group. The adjustment range is A–J.

04) Press the **SET button (07)** to save changes.

### 2. Channel

In this menu you can set the desired channel.

01) Press the **UP/DOWN buttons (05/06)** until the display shows:



02) Press the **SET button (07)** to edit.

03) Press the **UP/DOWN buttons (05/06)** to select the desired channel. The adjustment range is 1–14.

04) Press the **SET button (07)** to save changes.

### 3. Freq

In this menu you can set the desired frequency.

01) Press the **UP/DOWN buttons (05/06)** until the display shows:

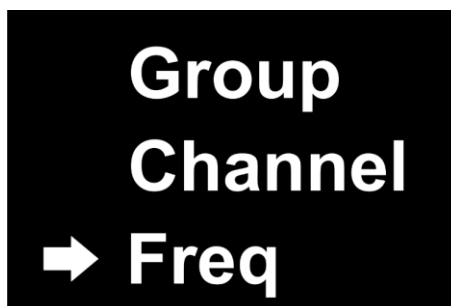

02) Press the **SET button (07)** to edit.

03) Press the **UP/DOWN buttons (05/06)** to select the desired frequency. The adjustment range is between 606–668 MHz.

04) Press the **SET button (07)** to save changes.



#### 4. Gain

In this menu you can set the transmitter gain.

01) Press the **UP/DOWN buttons (05/06)** until the display shows:



02) Press the **SET button (07)** to edit.

03) Press the **UP/DOWN buttons (05/06)** to set the desired gain. The adjustment range is from -32 dB to +4 dB.

04) Press the **SET button (07)** to save changes.

#### 5. RF Power

In this menu you can set the RF power.

01) Press the **UP/DOWN buttons (05/06)** until the display shows:

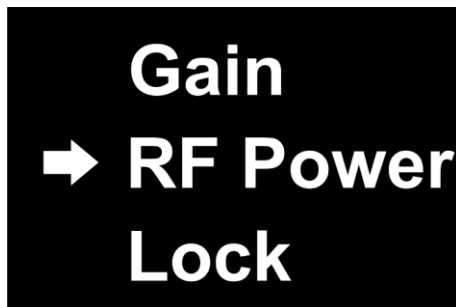

02) Press the **SET button (07)** to edit.

03) Press the **UP/DOWN buttons (05/06)** to select one of the 3 options:

- LOW (10 mW)
- MID (20 mW)
- HIGH (30 mW)

04) Press the **SET button (07)** to confirm.

Note: The maximum allowed RF output is 10 mW. The use of outputs stronger than 10 mW must be permitted by the local authorities.

## 6. Lock

In this menu you can lock the transmitter's display.

01) Press the **UP/DOWN buttons (05/06)** until the display shows:

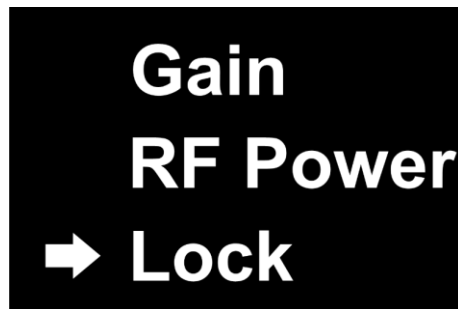

02) Press the **SET button (07)** to edit.

03) Press the **UP/DOWN buttons (05/06)** to select ON or OFF.

04) Press the **SET button (07)** to confirm.

05) If you have chosen ON, the display will be locked.

06) In order to unlock the display, press and hold down the **SET button (07)** for 4 seconds, until the receiver lock symbol disappears and you can access the main menu.

## Connection Cables

Take care of your cables, always holding them by the connectors and avoiding knots and twists when coiling them: This gives the advantage of increasing their life and reliability. Periodically check your cables. A great number of problems (faulty contacts, ground hum, discharges, etc.) are caused entirely by using unsuitable or faulty cables.

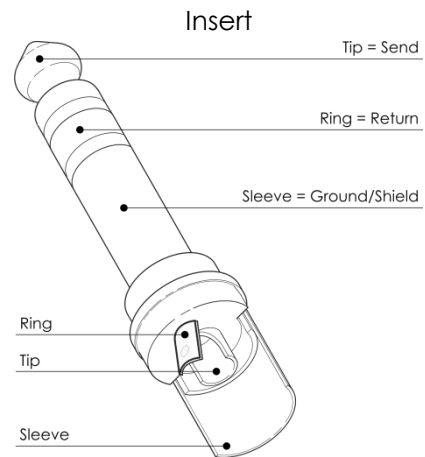
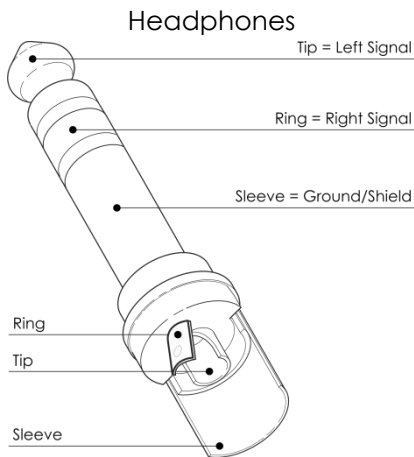
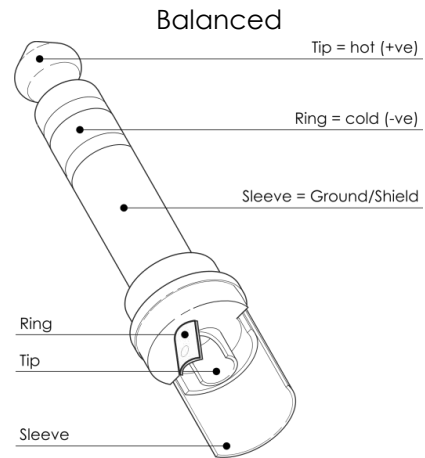
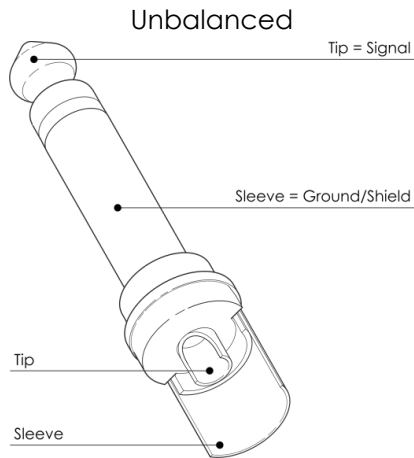

For these applications the unit provides 1/4" TRS and XLR connectors to easily interface with most professional audio devices. Follow the configuration examples below for your particular connection.

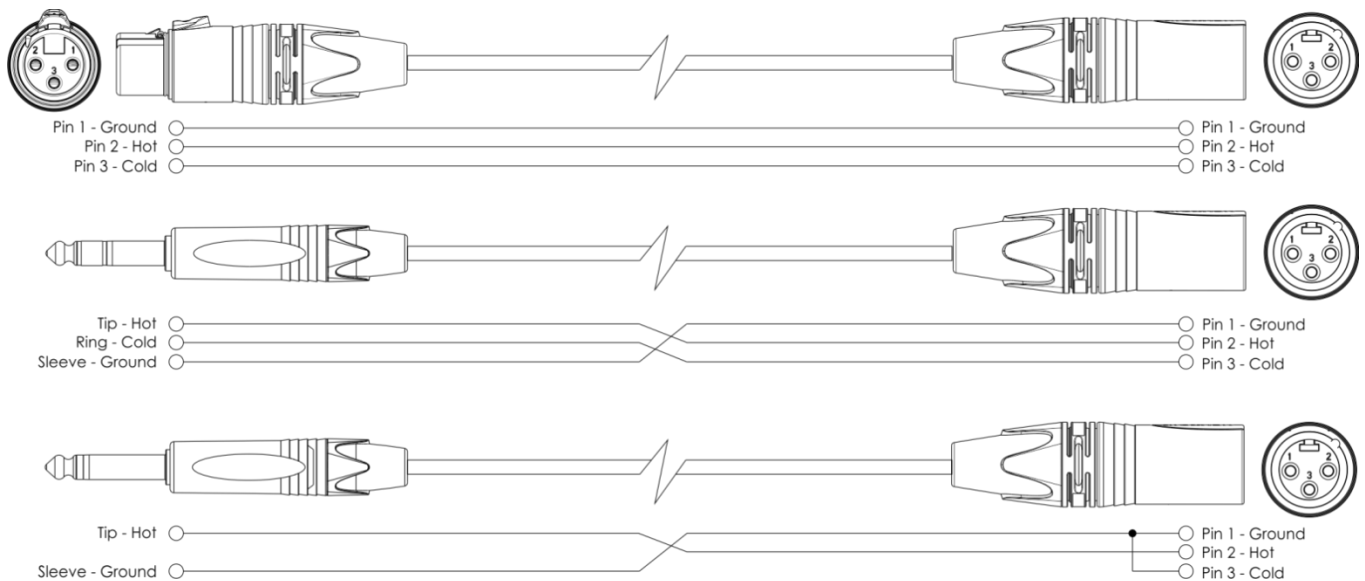

## Maintenance

The DAP Audio EDGE EHS-1 requires almost no maintenance. However, you should keep the unit clean. Disconnect the mains power supply, and then wipe the cover with a damp cloth. Do not immerse in liquid. Do not use alcohol or solvents.

Keep connections clean. Disconnect electric power, and then wipe the audio connections with a damp cloth. Make sure connections are thoroughly dry before linking equipment or supplying electric power.

## Troubleshooting

DAP Audio EDGE EHS-1

This troubleshooting guide is meant to help solve simple problems. If you are unable to determine the cause of the problem, do not open the unit, as this may damage the device and the warranty will be deemed void. Return the device to your DAP Audio dealer.

Problem	Solution
No sound	<ul style="list-style-type: none"> <li>• Make sure the transmitter is on.</li> <li>• Make sure the batteries are inserted properly. If the batteries are inserted properly, replace them with a set of new batteries.</li> <li>• Make sure the battery housing is clean.</li> </ul>
No sound	<ul style="list-style-type: none"> <li>• Make sure the DC power adapter is plugged into the appropriate power outlet and into the <b>DC power connector IN (23)</b> on the receiver. Make sure the AC electrical output works and supplies proper voltage.</li> </ul>
No sound	<ul style="list-style-type: none"> <li>• Turn up the volume on the receiver and/or the transmitter and/or the speaker.</li> <li>• Make sure the output connections between the receiver and external equipment are in order.</li> </ul>
No sound	<ul style="list-style-type: none"> <li>• Make sure that the transmitter and the receiver use the same frequency.</li> <li>• Move the transmitter closer to the receiver.</li> </ul>
Bursts of noise or other audible signals present	<ul style="list-style-type: none"> <li>• Adjust the squelch threshold.</li> <li>• Identify potential sources of interference (other RF sources) and turn them off.</li> </ul>
Momentary loss of sound as transmitter is moved around the performance area.	<ul style="list-style-type: none"> <li>• Reposition the receiver and perform a walk-through test again. If audible drop-outs persist, mark the dead spots and avoid them during performance.</li> </ul>
Bad reception	<ul style="list-style-type: none"> <li>• Check the antennas.</li> </ul>

## Approval

The DAP Audio EDGE EHS-1 is a Class 2 wireless audio device (Commission Decision 2000/299/EC).

Frequency range: 606–668 MHz

	BE	BG	CZ	DK	DE	EE	IE	EL	ES	
	FR	HR	IT	CY	LV	LT	LU	HU	MT	
	NL	AT	PL	PT	RO	SI	SK	FI	SE	UK

### Exclusion of liability

The frequency ranges available for wireless microphones differ per country and region. Consult the respective national and/or regional authorities as licensing or specific restrictions may apply for the use of the device. We do not take any responsibility in case the device cannot operate or be used in your country/region or if it requires additional licensing. Before using the device, check the allowed frequencies in your country or region.

**Be aware that in some countries you are allowed to partly use the frequency range of the device. Consult your local authorities for the latest information and regulations.**

Spectrum authorities in the EU countries:

Belgium	Belgian Institute for Postal Services and Communications	<a href="http://www.bipt.be">www.bipt.be</a>
Bulgaria	Communications Regulation Commission	<a href="http://www.crc.bg">www.crc.bg</a>
Czech Republic	Czech Telecommunication Office	<a href="http://www.ctu.cz">www.ctu.cz</a>
Denmark	Danish Energy Agency	<a href="http://www.ens.dk">www.ens.dk</a>
Germany	Die Bundesnetzagentur	<a href="http://www.bundesnetzagentur.de">www.bundesnetzagentur.de</a>
Estonia	Technical Regulatory Authority	<a href="http://www.tja.ee">www.tja.ee</a>
Ireland	Commission for Communications Regulation	<a href="http://www.comreg.ie">www.comreg.ie</a>
Greece	Hellenic Telecommunications and Post Commission	<a href="http://www.eett.gr">www.eett.gr</a>
Spain	Secretaría de Estado para el Avance Digital	<a href="http://www.mineco.gob.es">www.mineco.gob.es</a>
France	Agence Nationale des Fréquences	<a href="http://www.anfr.fr">www.anfr.fr</a>
Croatia	Regulatory Authority for Network Industries	<a href="http://www.hakom.hr">www.hakom.hr</a>
Italy	Istituto Superiore delle Comunicazioni e delle Tecnologie dell'Informazione	<a href="http://www.isticom.it">www.isticom.it</a>
Cyprus	Department of Electronic Communications	<a href="http://www.mcw.gov.cy">www.mcw.gov.cy</a>
Latvia	Electronic Communications Office	<a href="http://www.vases.lv">www.vases.lv</a>
Lithuania	Communications Regulatory Authority	<a href="http://www.rtt.lt">www.rtt.lt</a>
Luxembourg	Institut Luxembourgeois de Régulation	<a href="http://www.ilr.lu">www.ilr.lu</a>
Hungary	National Communications Authority	<a href="http://www.nmhh.hu">www.nmhh.hu</a>
Malta	Malta Communications Authority	<a href="http://www.mca.org.mt">www.mca.org.mt</a>
Netherlands	Agentschap Telecom	<a href="http://www.agentschaptelecom.nl">www.agentschaptelecom.nl</a>
Austria	Rundfunk und Telekom Regulierungs-GmbH	<a href="http://www.rtr.at">www.rtr.at</a>
Poland	Office of Electronic Communications	<a href="http://www.uke.gov.pl">www.uke.gov.pl</a>
Portugal	Autoridade Nacional de Comunicações	<a href="http://www.anacom.pt">www.anacom.pt</a>
Romania	National Authority for Management and Regulation in Communications	<a href="http://www.ancom.org.ro">www.ancom.org.ro</a>
Slovenia	Agency for Communication Networks and Services	<a href="http://www.akos-rs.si">www.akos-rs.si</a>
Slovakia	Regulatory Authority for Electronic Communications and Postal Services	<a href="http://www.teleoff.gov.sk">www.teleoff.gov.sk</a>
Finland	Finnish Transport and Communications Agency	<a href="http://www.traficom.fi">www.traficom.fi</a>
Sweden	Post and Telecom Authority	<a href="http://www.pts.se">www.pts.se</a>
United Kingdom	Office of Communications	<a href="http://www.ofcom.org.uk">www.ofcom.org.uk</a>

## Spectrum authorities in the EFTA countries:

Iceland	Post and Telecom Administration	<a href="http://www.pfs.is">www.pfs.is</a>
Liechtenstein	Amt für Kommunikation	<a href="http://www.llv.li">www.llv.li</a>
Norway	Norwegian Communications Authority	<a href="http://www.nkom.no">www.nkom.no</a>
Switzerland	Federal Office of Communications	<a href="http://www.bakom.admin.ch">www.bakom.admin.ch</a>

## Spectrum authorities in the EU candidate countries:

Montenegro	Agency for Electronic Communications and Postal Services	<a href="http://www.ekip.me">www.ekip.me</a>
Republic of North Macedonia	Agency for Electronic Communications	<a href="http://www.aek.mk">www.aek.mk</a>
Albania	Electronic and Postal Communications Authority	<a href="http://www.akep.al">www.akep.al</a>
Serbia	Regulatory Agency for Electronic Communications and Postal Services	<a href="http://www.ratel.rs">www.ratel.rs</a>
Turkey	Information and Communications Technologies Authority	<a href="http://www.btk.gov.tr">www.btk.gov.tr</a>

## Product Specifications

Model:	DAP Audio EDGE EHS-1
Power supply:	DC 12–15 V, 300 mA
Dimensions (transmitter):	Ø51 mm x 255 mm (WxH)
Dimensions (receiver):	205 x 170 x 263 mm (LxWxH)
Weight (transmitter):	0,4 kg
Weight (receiver):	1,24 kg
<b>Receiver:</b>	
Modulation:	FM
Frequency range:	606–668 MHz
Frequency response:	75 Hz–18 kHz
Sensitivity:	-100 dBm/30 dB sinad
Distortion:	<1%(AF1 kHz, RF46 dBu)
Max SPL:	128 dB SPL
RF stability:	≤ ± 15 ppm
Frequency deviation:	± 75 kHz
Spurious rejection:	>50 dB
SNR:	>100 dBA
Transmission latency:	0 ms
Audio outputs:	3-pin XLR OUT balanced, mono 1/4" jack unbalanced
Pilot frequency:	32768 kHz
Output signal sensitivity adjustable range:	48 dB, Adopt 6 dB step for adjustment
Indicators:	A/B antenna, AF signal
<b>Transmitter:</b>	
Type microphone:	Dynamic
Output gain range:	30 dB
RF output:	10 mW/20 mW/30 mW
Power supply:	2 x AA 1,5 V batteries (not included)
Max. ambient temperature $t_a$ :	40 °C
Max. housing temperature $t_B$ :	70 °C

Design and product specifications are subject to change without prior notice.



Website: [www.Dap-audio.info](http://www.Dap-audio.info)

Email: [service@highlite.com](mailto:service@highlite.com)

## Dimensions

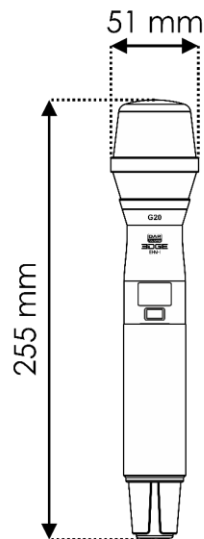
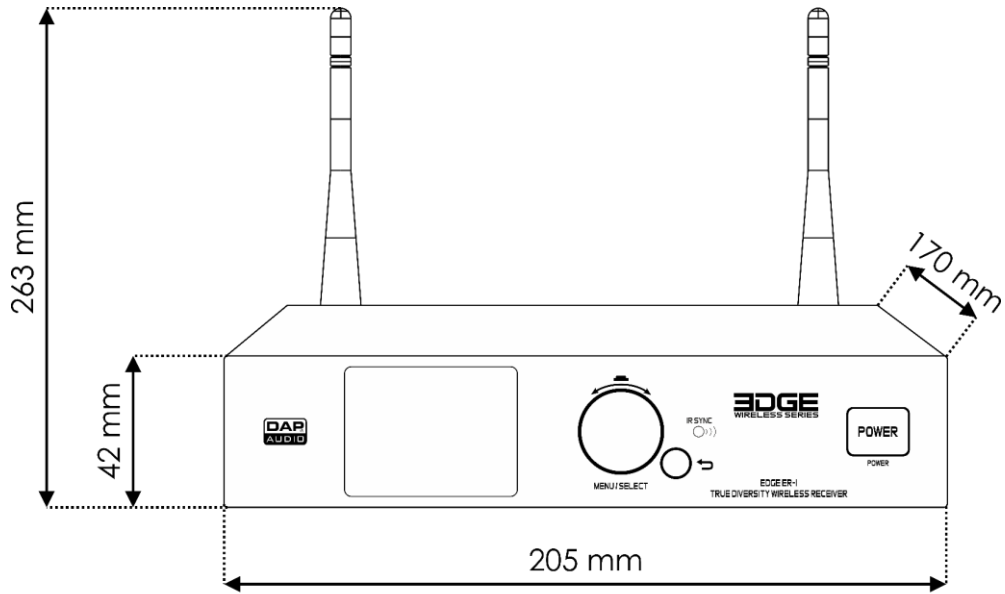



©2020 DAP Audio