

MAN061.80

Lavoce

6.5" MIDRANGE

NEODYMIUM MAGNET
ALUMINIUM BASKET DRIVER



- 1.8 INCH CCAW VOICE COIL
- 95,5 dB/SPL SENSITIVITY
- 300 WATT PROGRAM POWER HANDLING
- FEM OPTIMIZED MOTOR AND SUSPENSIONS
- OPTIMIZED COOLING SYSTEM
- COPPER RING FOR EXTENDED FREQUENCY RESPONSE
- RESONANCE FREE AND HEAVY DUTY BASKET DESIGN
- TRIPLE ROLL SURROUND

GENERAL SPECIFICATIONS

Nominal diameter	mm (in.)	165 (6.5)
Nominal impedance	Ω	8
Minimum impedance	Ω	6,6
Program power (1)	W	300
AES Power rating (2)	W	150
Sensitivity (3)	dB	95,5
Frequency range	Hz	170 ÷ 6000
Voice coil diameter	mm (in.)	45 (1.8)
Chassis material	Aluminium	
Magnet material	Neodymium	
Magnet dimensions OD x ID x h	mm (in.)	85 x 55 x 7 (3.35 x 2.2 x 0.28)
Coil material	CCAW	
Former material	Glass Fiber	
Cone material	Water Proof Treated Paper	
Surround material	Polycotton	
Xmax (4)	mm (in.)	3 (0.12)
Xmech (5)	mm (in.)	5,5 (0.22)
Gap height	mm (in.)	6 (0.24)
Voice coil winding height	mm (in.)	9 (0.35)
Driver displacement volume	l (ft ³)	0,4 (0.01)

SMALL SIGNAL PARAMETERS

DC resistance	Re	Ohm	5,5
Resonance frequency	Fs	Hz	170
Moving mass	Mms	g (oz)	13 (0.46)
Compliance	Cms	mm/N	0,07
Force factor	BxL	N/A	11,0
Mechanical Q-factor	Qms		4,5
Electrical Q-factor	Qes		0,60
Total Q-factor	Qts		0,54
Equivalent air volume	Vas	l (ft ³)	2 (0.07)
Voice coil Inductance	Le	mH	0,08
Diaphragm area	Sd	cm ² (in. ²)	137 (21.24)
Reference efficiency	Eta 0	%	1,50

SHIPPING INFORMATION

Net weight	kg (lb.)	1,2 (2.5)
Multipack size (8)	mm (in.)	410 x 370 x 208 (16.1 x 14.6 x 8.2)
Multipack weight	kg (lb.)	12,8 (28.2)

FREQUENCY RESPONSE

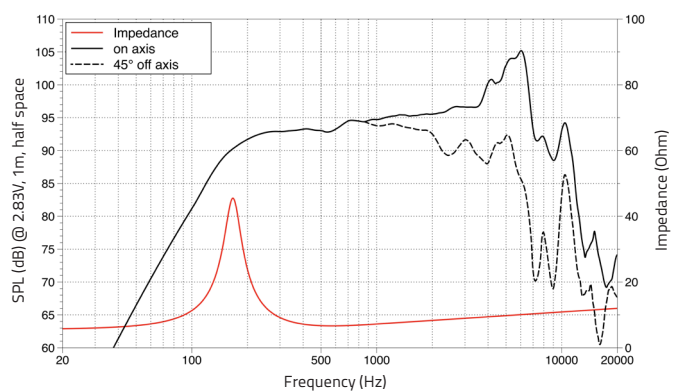

DIMENSIONS mm (in.)

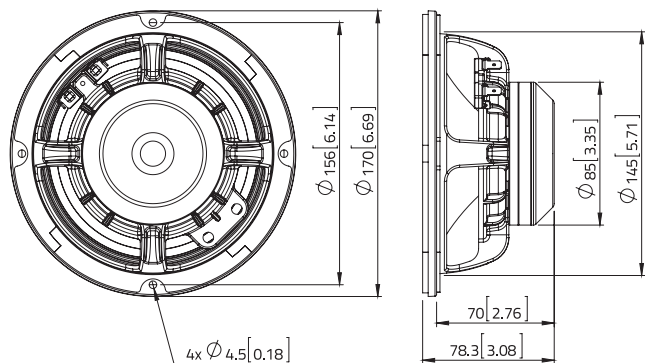

(1) Program power is defined as 3 dB greater than AES Power. (2) Tested for two hours using a continuous, band-limited pink noise signal as per AES 2-1984 Rev. 2003. Loudspeaker tested in free air. (3) From T/S parameters, measured with Klippel DA LPM module. (4) The Xmax is calculated as: $(Hvc - Hg)/2 + Hg/4$. Hvc is the voice coil height and Hg the gap height. (5) The Xmech is calculated as: $(Hvc - Hg)/2 + (Hg - 2)$. Hvc is the voice coil height and Hg the gap height. (6) Thiele-Small parameters are measured after preconditioning: a) at 20°C - 22°C, 50% humidity for 2 hours; b) by Klippel LSI measurement.

All specifications subject to change without notice_B.a

