

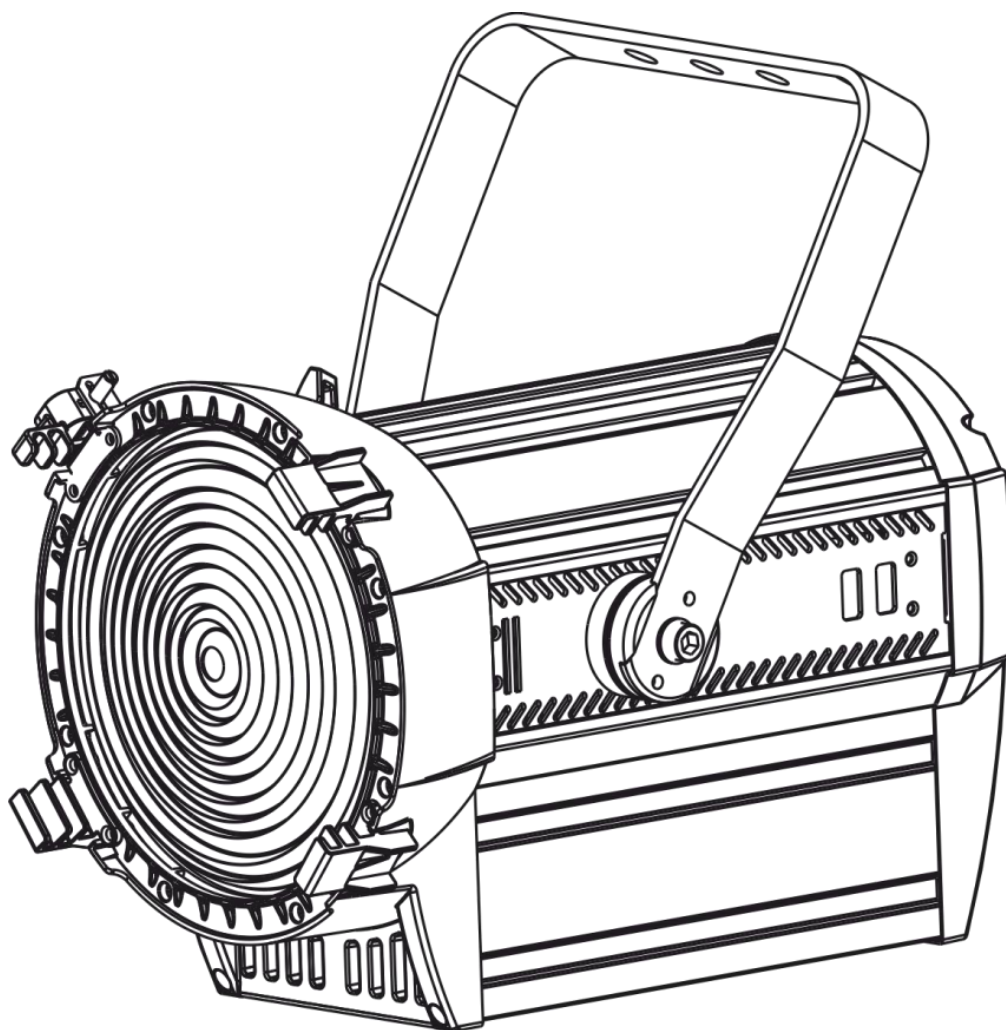

MANUAL



ENGLISH

Performer 2000 Fresnel DDT MKII V1

Ordercode: 33037

Table of contents

Warning	3
Safety Instructions	3
Operating Determinations	5
Rigging	5
Connection with the mains	6
Return Procedure	7
Claims	7
Description of the device	8
Features	8
Overview	8
Backside	10
Installation	11
Set Up and Operation	11
Color frame retaining clip	11
Setting the angle	12
Control Modes	13
One Performer (Stand-alone)	13
Multiple Performers (Master/Slave control)	13
Multiple Performers (DMX Control)	14
Fixture Linking	15
Data Cabling	15
Control Panel	16
Control Mode	16
DMX Addressing	16
Menu Overview	17
Main Menu Options	18
1. DMX-512 Mode	18
2. Run Mode	18
3. Zoom/Dimmer settings	19
4. White color calibration	19
5. General settings	20
5.1. Dimming curve settings	20
5.2. Dimmer speed	21
5.3. Safety key	21
5.4. DMX data transfer	21
5.5. Performance settings	21
5.6. Zoom range settings	21
5.7. Save DMX/Blackout	22
5.8. Settings lock	22
5.9. DMX channel modes	22
5.10. Reset settings	22
6. Motor reset	22
DMX Channels	23
1 Channel	23
2 Channels	23
5 Channels	23
Cleaning	24
Cleaning the glass lens	24
Maintenance	24
Replacing the Fuse	24

Troubleshooting25
 No Light25
 No Response to DMX.....25

Product Specifications27

Dimensions.....28

Notes29

Warning



**For your own safety, please read this user manual carefully
before your initial start-up!**



Unpacking Instructions

Immediately upon receiving this product, carefully unpack the carton and check the contents to ensure that all parts are present, and have been received in good condition. Notify the dealer immediately and retain packing material for inspection if any parts appear damaged from shipping or the carton itself shows signs of mishandling. Save the carton and all packing materials. In the event that a fixture must be returned to the factory, it is important that the fixture be returned in the original factory box and packing.

Your shipment includes:

- Showtec Performer 2000 Fresnel DDT MKII
- 1 color frame
- 1 safety cable
- User manual

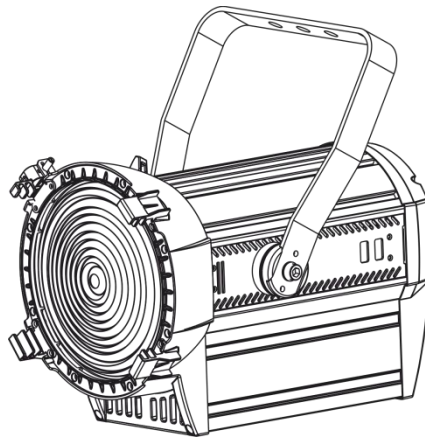

LED Expected Lifespan

LEDs gradually decline in brightness over time. HEAT is the dominant factor that leads to the acceleration of this decline. Packaged in clusters, LEDs exhibit higher operating temperatures than in ideal or singular optimum conditions. For this reason, when all color LEDs are used at their fullest intensity, life of the LEDs is significantly reduced. If improving the lifespan is of higher priority, place care in providing for lower operational temperatures. This may include climatic-environmental and the reduction of overall projection intensity.



CAUTION!

**Keep this device away from rain and moisture!
Unplug mains lead before opening the housing!**



Safety Instructions

Every person involved with the installation, operation and maintenance of this device has to:

- be qualified
- follow the instructions of this manual



**CAUTION! Be careful with your operations.
With a dangerous voltage you can suffer
a dangerous electric shock when touching the wires!**



Before the initial start-up, please make sure that there is no damage caused by transportation. Should there be any, consult your dealer and do not use the device.

To maintain perfect condition and to ensure a safe operation, it is absolutely necessary for the user to follow the safety instructions and warning notes contained in this manual.

Please consider that damages caused by manual modifications to the device are not subject to warranty.

This device contains no user-serviceable parts. Refer servicing to qualified technicians only.

IMPORTANT:

The manufacturer will not accept liability for any resulting damages caused by the non-observance of this manual or any unauthorized modification to the device.

- Never let the power cord come into contact with other cables! Handle the power cord and all connections with the mains with particular caution!
- Never remove warning or informative labels from the unit.
- Never use anything to cover the ground contact.
- Never lift the fixture holding it by the projector-head, as the mechanics may be damaged. Always hold the fixture by the transport handles.
- Never place any material over the lens.
- Never look directly into the light source.
- Never leave any cables lying around.
- Do not insert objects into air vents.
- Do not connect this device to a dimmerpack.
- Do not switch the device on and off in short intervals, as this will reduce the device's life.
- Do not touch the device's housing bare-handed during its operation (housing becomes very hot). Allow the fixture to cool for at least 5 minutes before handling.
- Do not shake the device. Avoid brute force when installing or operating the device.
- Only use the device indoors, avoid contact with water or other liquids.
- Only operate the fixture after having checked if the housing is firmly closed and all screws are tightly fastened.
- Only operate the device after having familiarized with its functions.
- Avoid flames and do not put close to flammable liquids or gases.
- Always keep the case closed while operating.
- Always allow a free air space of at least 50 cm around the unit for ventilation.
- Always disconnect power from the mains, when device is not used or before cleaning! Only handle the power cord holding it by the plug. Never pull out the plug by tugging the power cord.
- Make sure that the device is not exposed to extreme heat, moisture or dust.
- Make sure that the available voltage is not higher than stated on the rear panel.
- Make sure that the power cord is never crimped or damaged. Check the device and the power cord from time to time.
- If the lens is obviously damaged, it has to be replaced.
- If device was dropped or struck, disconnect mains power supply immediately. Have a qualified engineer inspect for safety before operating.
- If the device has been exposed to drastic temperature fluctuation (e.g. after transportation), do not switch it on immediately. The arising condensation water might damage your device. Leave the device switched off until it has reached room temperature.
- If your Showtec device fails to work properly, discontinue the use immediately. Pack the unit securely (preferably in the original packing material), and return it to your Showtec dealer for service.
- For adult use only. Never leave the unit running unattended.
- Never attempt to bypass the thermostatic switch or fuses.
- For replacement use fuses of same type and rating only.
- The user is responsible for correct positioning and operating of the Performer. The manufacturer will not accept liability for damages caused by the misuse or incorrect installation of this device.
- This device falls under protection class I. Therefore it is essential to connect the yellow/green conductor to earth.

- Repairs, servicing and electric connection must be carried out by a qualified technician.
- WARRANTY: Till one year after date of purchase.

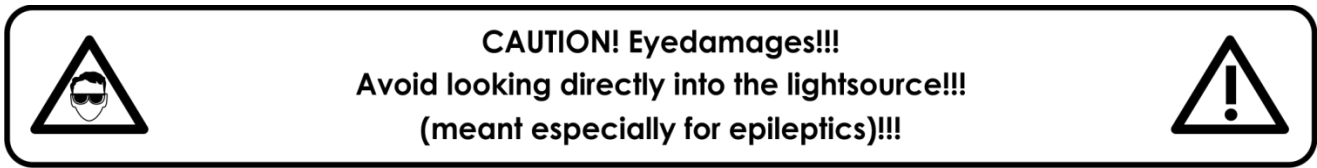

Operating Determinations

- This device is not designed for permanent operation. Consistent operation breaks will ensure that the device will serve you for a long time without defects.
- The minimum distance between light output and the illuminated surface must be bigger than 1 meter.
- The maximum ambient temperature $t_a = 40^\circ\text{C}$ must never be exceeded.
- The relative humidity must not exceed 50 % with an ambient temperature of 40°C .
- If this device is operated in any other way than the one described in this manual, the product may suffer damages and the warranty becomes void.
- Any other operation may lead to dangers like short-circuit, burns, electric shock, crash, etc.

You endanger your own safety and the safety of others!

Rigging

Please follow the European and national guidelines concerning rigging, trussing and all other safety issues.

Do not attempt the installation yourself !

Always let the installation be carried out by an authorized dealer !

Procedure:

- If the projector is lowered from the ceiling or high joists, professional trussing systems have to be used.
- Use a clamp to mount the projector, with the mounting bracket, to the trussing system.
- The projector must never be fixed swinging freely in the room.
- The installation must always be secured with a safety attachment, e.g. an appropriate safety net or safety cable.
- When rigging, derigging or servicing the projector, always make sure, that the area below the installation site is secured and that there are not any unauthorized people around.

Improper installation can cause serious injuries and/or damage of property!

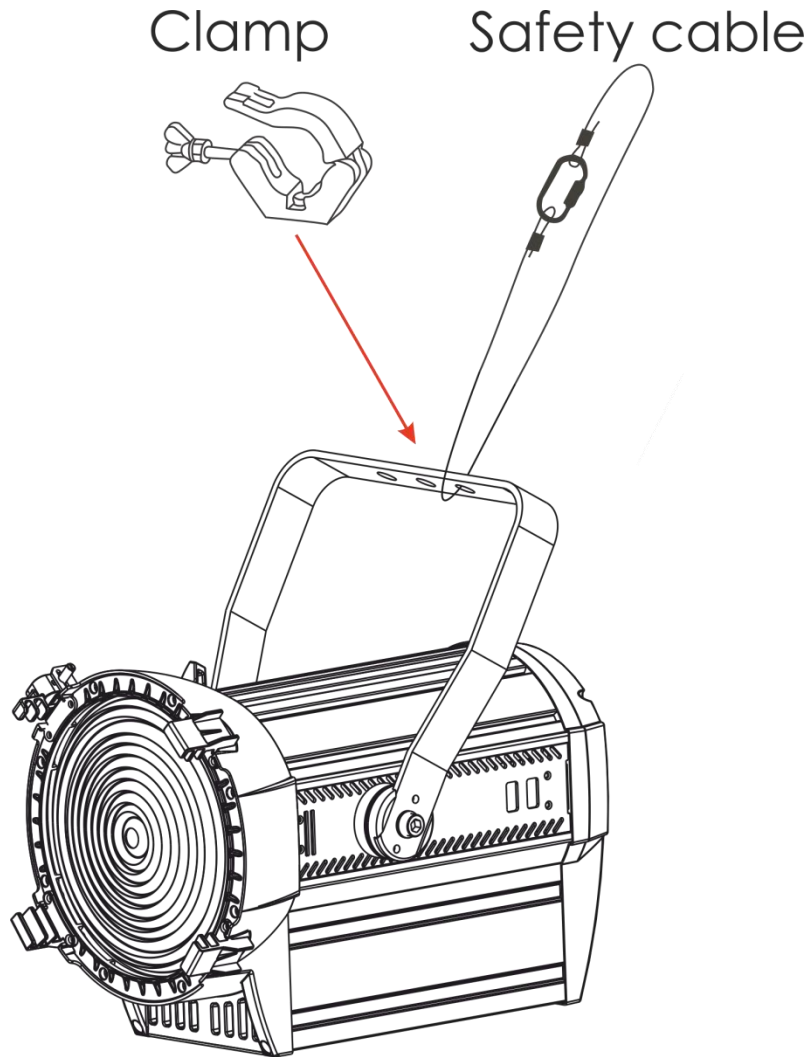

Connection with the mains

Connect the device to the mains with the power-plug.
Always check if the right color cable is connected to the right place.

International	EU Cable	UK Cable	US Cable	Pin
L	BROWN	RED	YELLOW/COPPER	PHASE
N	BLUE	BLACK	SILVER	NEUTRAL
⊕	YELLOW/GREEN	GREEN	GREEN	PROTECTIVE GROUND

Make sure that the device is always properly connected to the earth!

Improper installation can cause serious injuries and/or damage of property!



Return Procedure



Returned merchandise must be sent prepaid and in the original packing, call tags will not be issued. Package must be clearly labeled with a Return Authorization Number (RMA number). Products returned without an RMA number will be refused. Highlite will not accept the returned goods or any responsibility. Call Highlite 0031-455667723 or mail offersales@highlite.nl and request an RMA prior to shipping the fixture. Be prepared to provide the model number, serial number and a brief description of the cause for the return. Be sure to properly pack fixture, any shipping damage resulting from inadequate packaging is the customer's responsibility. Highlite reserves the right to use its own discretion to repair or replace product(s). As a suggestion, proper UPS packing or double-boxing is always a safe method to use.

Note: If you are given an RMA number, please include the following information on a piece of paper inside the box:

- 01) Your name
- 02) Your address
- 03) Your phone number
- 04) A brief description of the symptoms

Claims

The client has the obligation to check the delivered goods immediately upon delivery for any shortcomings and/or visible defects, or perform this check after our announcement that the goods are at their disposal. Damage incurred in shipping is the responsibility of the shipper; therefore the damage must be reported to the carrier upon receipt of merchandise.

It is the customer's responsibility to report and submit claims with the shipper in the event that a fixture is damaged due to shipping. Transportation damage has to be reported to us within one day after receipt of the delivery.

Any return shipment has to be made post-paid at all times. Return shipments must be accompanied with a letter defining the reason for return shipment. Non-prepaid return shipments will be refused, unless agreed otherwise in writing.

Complaints against us must be prepared in writing or sent by fax within 10 working days after receipt of the invoice. After this period complaints will not be handled anymore.

Complaints will only then be considered if the client has so far complied with all parts of the agreement, regardless of the agreement from which the obligation is resulting.

Description of the device

Features

The Showtec Performer 2000 Fresnel DDT MKII is a theater spotlight fixture with high output and great effects.

- Input voltage: 100-240V AC, 60/50Hz
- Light source: 1x 200W CITIZEN LED
- Power consumption: 180W
- Light output: 6370 Lumen
- Peak intensity: 100333 cd
- Color rendering: >90Ra
- Color temperature: 3200K
- Dimmer: 0-100%
- Dim curve: Dimm4 technology, 4 presets
- Strobe: 0-20Hz
- Motorized zoom: 13-41°
- Control modes: Stand-alone, Master/Slave, DMX -512
- Connections: 3-pin/5-pin XLR signal connectors IN/OUT, PowerCON power connectors IN/OUT
- Refresh rate: 600Hz-25000Hz
- Power linking: 3 units @ 120V; 6 units @ 240V
- DMX channels: 1, 2, 5 channels
- Extremely quiet
- Housing: Die-cast aluminum & flame-retardant plastic
- Cooling: Internal fan
- IP rating: IP20
- Fuse: T3,15AL/250V
- Dimensions: 255 x 380 x 388 mm (LxWxH)
- Weight: 6,8 kg

Overview

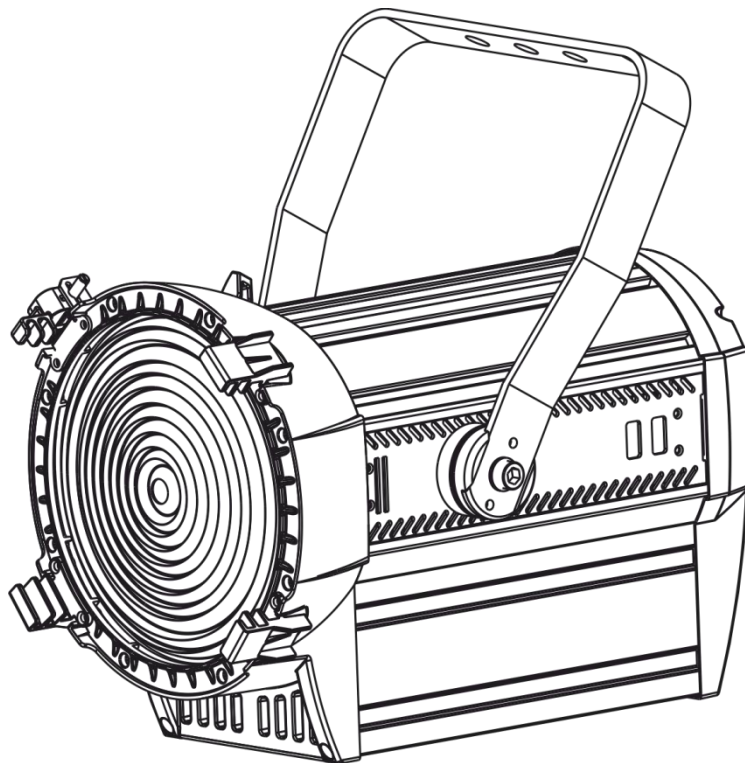

Fig. 01

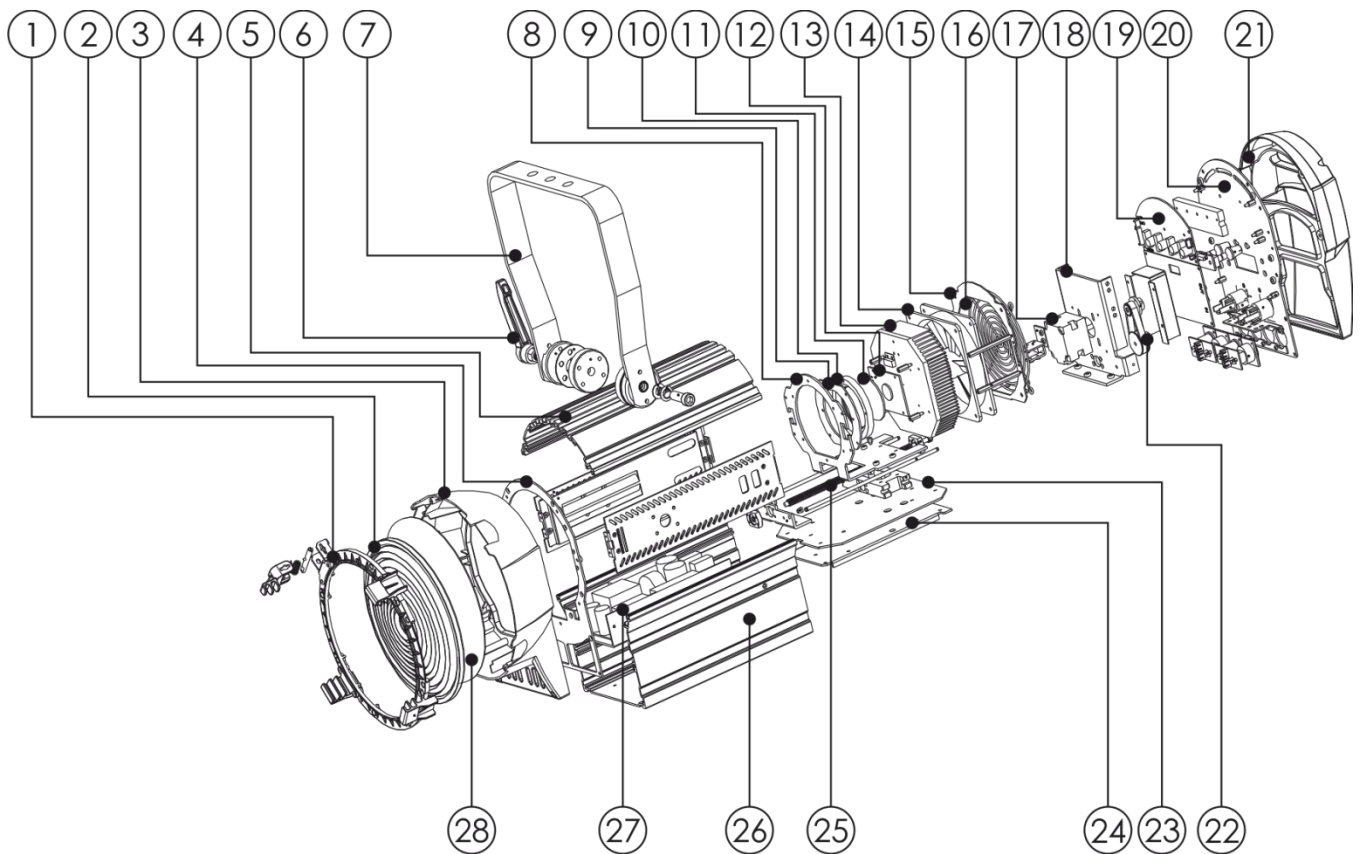

Fig. 02

- 01) Front cap
- 02) Front lens cover
- 03) Lens tube
- 04) Front plate
- 05) Top cover
- 06) Adjustment screw
- 07) Mounting bracket with inclination screw
- 08) Heat-sink bracket
- 09) Lens plate
- 10) Lens frame
- 11) Collecting lens
- 12) LED board
- 13) Thermal switch holder
- 14) Cooling fan
- 15) Cooling fan frame
- 16) Air intake grill
- 17) Motor
- 18) Motor frame
- 19) PCB
- 20) Rear plate
- 21) Rear cover
- 22) Transmission belt
- 23) Focus bracket
- 24) Focus bracket support
- 25) Screw shaft
- 26) Bottom cover
- 27) Power supply
- 28) Lens filter

Backside

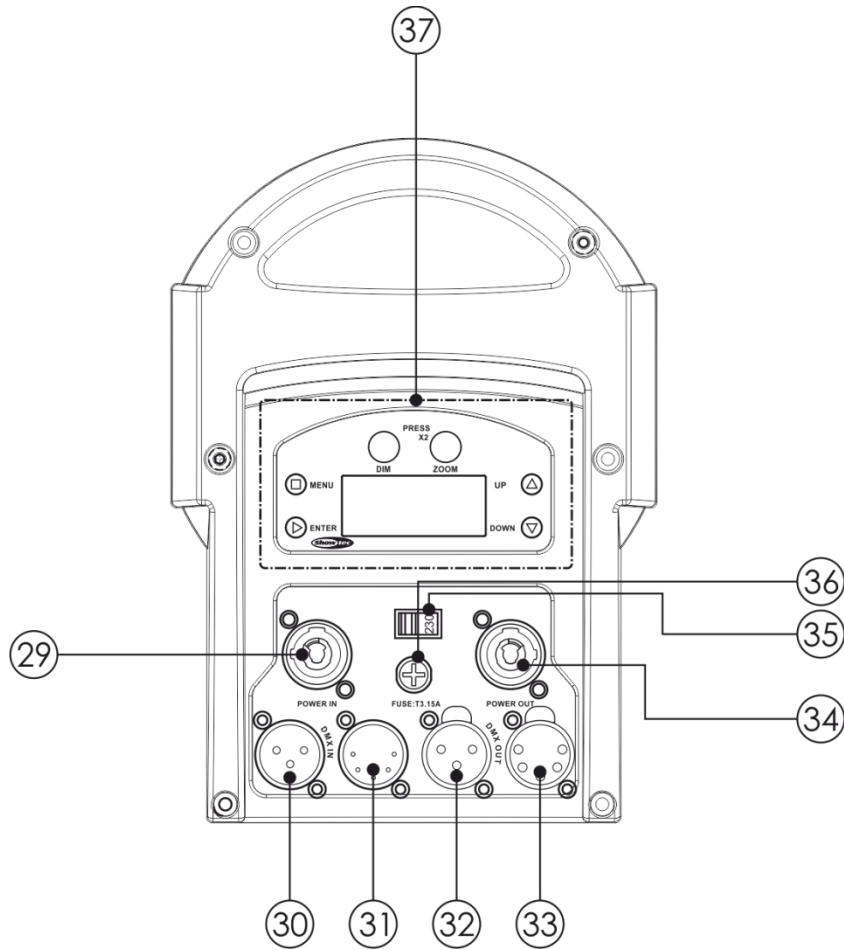

Fig. 03

- 29) PowerCON power connector 100-240V IN
- 30) 3-pin DMX signal connector IN
- 31) 5-pin DMX signal connector IN
- 32) 3-pin DMX signal connector OUT
- 33) 5-pin DMX signal connector OUT
- 34) PowerCON power connector 100-240V OUT
- 35) Voltage switch 115/230V
- 36) Fuse T3, 15A/250V
- 37) LED display + menu buttons

Installation

Remove all packing materials from the Performer 2000 Fresnel DDT MKII. Check if all foam and plastic padding is removed. Connect all cables.

Do not supply power before the whole system is set up and connected properly.

Always disconnect from electric mains power supply before cleaning or servicing.

Damages caused by non-observance are not subject to warranty.

Set Up and Operation

Follow the directions below, as they pertain to your preferred operation mode.

Before plugging the unit in, always make sure that the power supply matches the product specification voltage. Do not attempt to operate a 120V specification product on 230V power, or vice versa.

Connect the device to the main power supply.

Color frame retaining clip

The color frame holder is equipped with a spring-loaded retaining clip. This prevents color frames and accessories from falling out.



Make sure that all color frame accessories are locked in position with the retaining clip before hanging the Performer 2000 Fresnel DDT MKII.



- 01) Release the retaining clip by pressing the lock towards the lens and pressing the longer side of the screw. The retaining clip will open.
- 02) Insert the color frame(s).
- 03) Lock the retaining clip by pressing the retaining clip towards the lens.

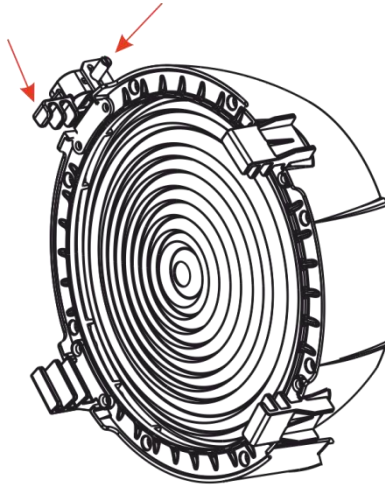

Retaining clip in unlocked position

Fig. 04

Setting the angle

- 01) Loosen the adjustment screw (do not remove them).
- 02) Tilt the fixture to the desired position.
- 03) Tighten the adjustment screw to secure the fixture in position.

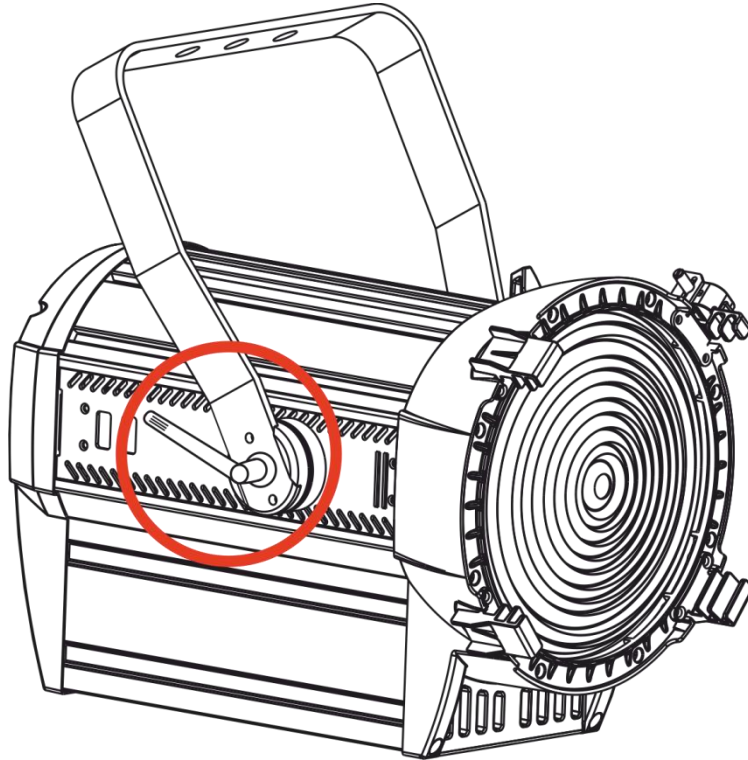

Fig. 05

Control Modes

There are 3 modes:

- Stand-alone
- Master/Slave
- DMX-512 (1CH, 2CH, 5CH)

One Performer (Stand-alone)

- 01) Fasten the effect light to a firm trussing. Leave at least 0,5 meter on all sides for air circulation.
- 02) Plug the end of the electric mains power cord into a proper electric power supply socket.
- 03) When the Performer is not connected with a DMX cable, it functions as a stand-alone device. Please see pages 18-22 for more information.

Multiple Performers (Master/Slave control)

- 01) Fasten the effect light onto firm trussing. Leave at least 0,5 meter on all sides for air circulation.
- 02) Use a 3-pin/5-pin XLR cable to connect the Performer.

The pins:



- 01) Earth
- 02) Signal -
- 03) Signal +

- 03) Link the units as shown in fig. 06. Connect the first unit's DMX "out" socket with the second unit's "in" socket, using a DMX-signal cable. Repeat this process to link the second, third, and fourth units. You can use the same functions on the master device as described on pages 18-22. This means that you can set your desired operation mode on the master device and all slave devices will react the same as the master device.

Multiple Performers (Master/Slave control)

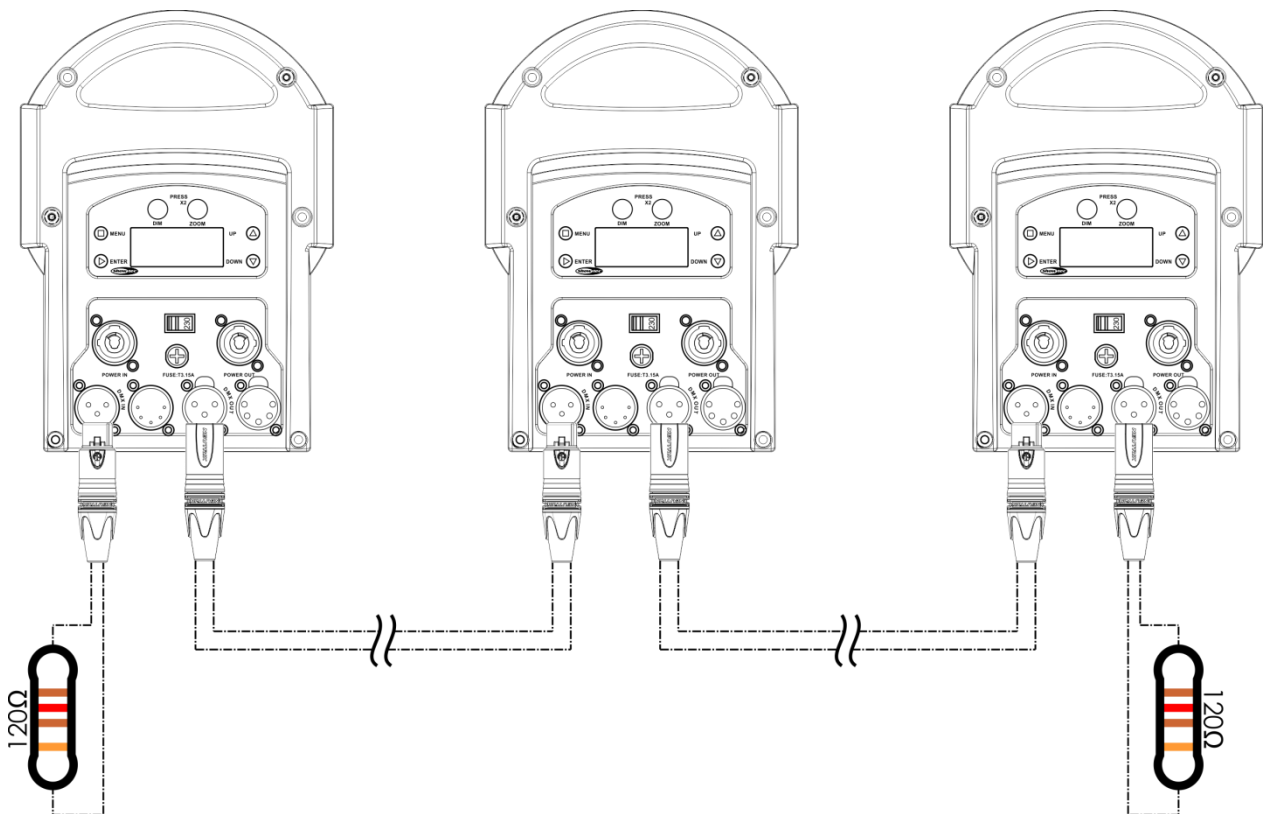
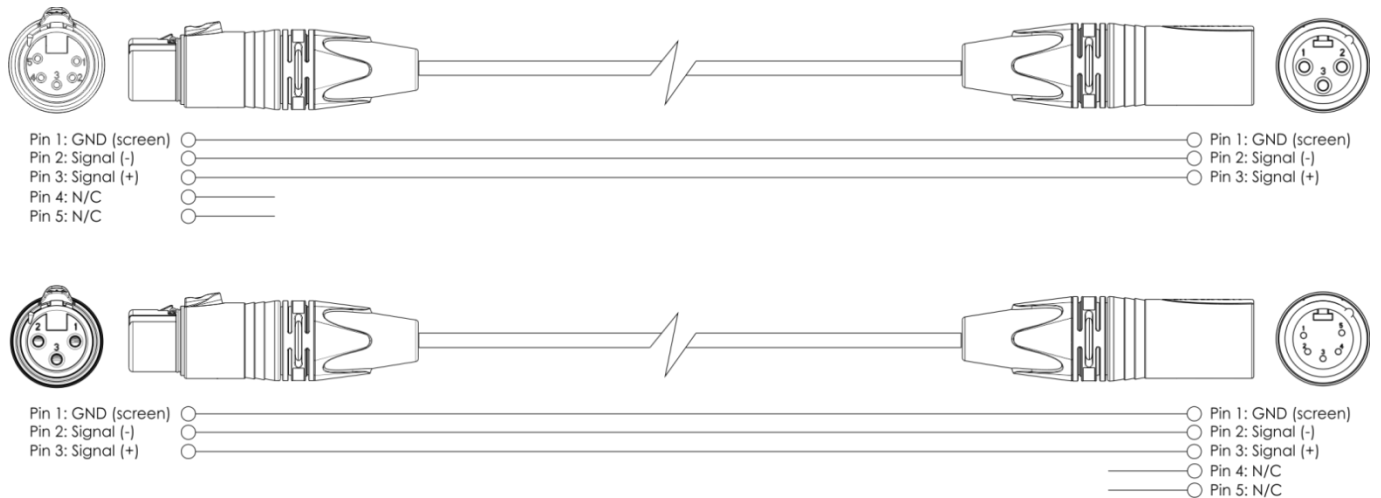

Fig. 06

Multiple Performers (DMX Control)

- 01) Fasten the effect light to a firm trussing. Leave at least 0,5 meter on all sides for air circulation.
- 02) Always use a safety cable (ordercode 70140 / 70141).
- 03) Use a 3-pin/5-pin XLR cable to connect the Performers and other devices.



- 04) Link the units as shown in fig. 07. Connect the first unit's DMX "out" socket with the second unit's "in" socket, using a DMX-signal cable. Repeat this process to link the second, third, and fourth units.
- 05) Supply electric power: Plug electric mains power cords into each unit's PowerCON socket, then plug the other end of the mains power cord into proper electric power supply sockets, starting with the first unit. Do not supply power before the whole system is set up and connected properly.

Multiple Performers DMX Set Up

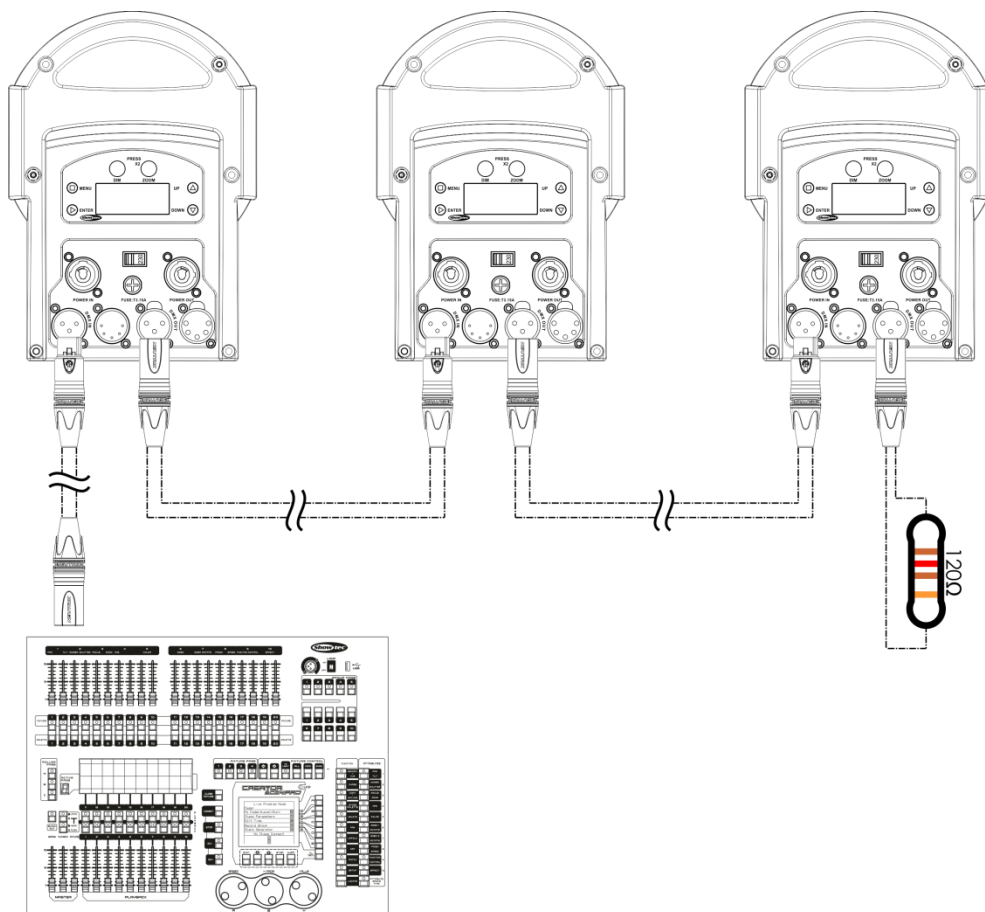

Fig. 07

Note : Link all cables before connecting electric power

Fixture Linking

You will need a serial data link to run light shows of one or more fixtures using a DMX-512 controller or to run synchronized shows of two or more fixtures set to a master/slave operating mode. The combined number of channels required by all the fixtures on a serial data link determines the number of fixtures the data link can support.

Important: Fixtures on a serial data link must be daisy-chained in a single line. To comply with the EIA-485 standard, no more than 30 devices should be connected on one data link. Connecting more than 30 fixtures on one serial data link without the use of a DMX optically isolated splitter may result in deterioration of the digital DMX signal.



Maximum recommended DMX data link distance: 100 meters

Maximum recommended number of fixtures on a DMX data link: 30 fixtures

Maximum recommended number of fixtures on a Powercon link: 3 units @120V

Maximum recommended number of fixtures on a Powercon link: 6 units @240V

Data Cabling

To link fixtures together, you must obtain data cables. You can purchase DAP Audio certified DMX cables directly from a dealer/distributor or construct your own cable. If you choose to create your own cable, please use data-grade cables that can carry a high quality signal and are less prone to electromagnetic interference.

DAP Audio DMX Data Cables

- DAP Audio Basic microphone cable for allround use. bal. XLR/M 3-pin > XLR/F 3-pin. **Ordercode** FL01150 (1,5 m), FL013 (3 m), FL016 (6 m), FL0110 (10 m), FL0115 (15 m), FL0120 (20 m).
- DAP Audio X-type data cable XLR/M 3-pin > XLR/F 3-pin. **Ordercode** FLX0175 (0,75 m), FLX01150 (1,5 m), FLX013 (3 m), FLX016 (6 m), FLX0110 (10 m).
- DAP Audio cable for the demanding user with exceptional audio-qualities and connector made by Neutrik®. **Ordercode** FL71150 (1,5 m), FL713 (3 m), FL716 (6 m), FL7110 (10 m).
- DAP Audio cable for the demanding user with exceptional audio-qualities and connector made by Neutrik®. **Ordercode** FL7275 (0,75 m), FL72150 (1,5 m), FL723 (3 m), FL726 (6 m), FL7210 (10 m).
- DAP Audio 110 Ohm cable with digital signal transmission. **Ordercode** FL0975 (0,75 m), FL09150 (1,5 m), FL093 (3 m), FL096 (6 m), FL0910 (10 m), FL0915 (15 m), FL0920 (20 m).

The Performer 2000 Fresnel DDT MKII can be operated with a controller in **control mode** or without the controller in **stand-alone mode**.

Control Panel

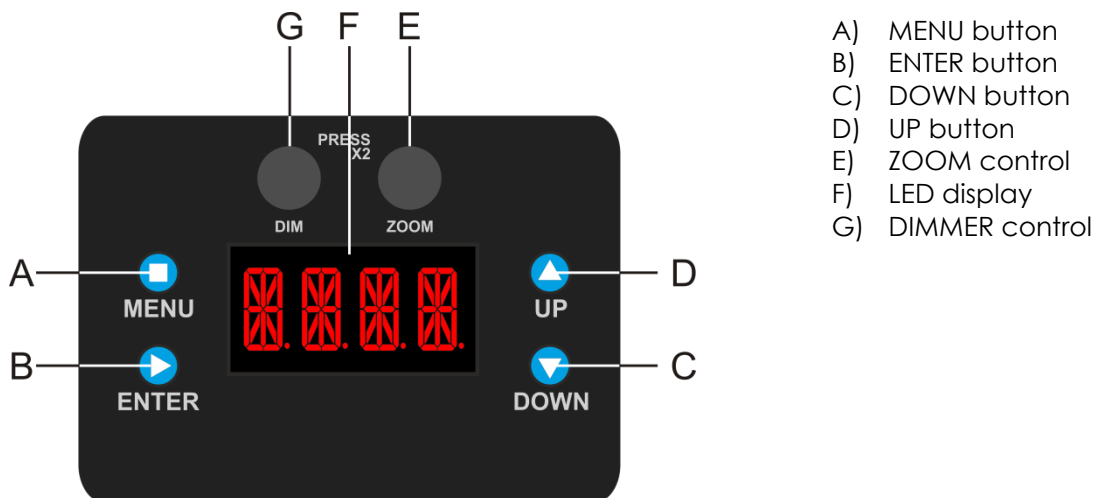

Fig. 08

Control Mode

The fixtures are individually addressed on a data-link and connected to the controller. The fixtures respond to the DMX signal from the controller. (When you select the DMX address and save it, the controller will display the saved DMX address, next time.)

DMX Addressing

The control panel on the front side of the base allows you to assign DMX fixture addresses, which is the first channel with which the Performer will respond to the controller.

Please note, when you use the controller, the unit has **5** channels.

When using multiple Performers, make sure you set the DMX addresses right.

Therefore, the DMX address of the first Performer should be **1(001)**; the DMX address of the second Performer should be **1+5=6 (006)**; the DMX address of the third Performer should be **6+5=11 (011)**, etc.

Please, be sure that you do not have any overlapping channels in order to control each Performer correctly. If two or more Performers are addressed similarly, they will work similarly.

Controlling:

After having addressed all Performer fixtures, you may now start operating these via your lighting controller.

Note: After switching on, the Performer will automatically detect whether DMX 512 data is received or not. If there is no data received at the DMX-input, the "LED" on the control panel will not flash.

If not, the problem may be:

- The XLR cable from the controller is not connected with the input of the Performer 2000 LED.
- The controller is switched off or defective, the cable or connector is defective, or the signal wires are swapped in the input connector.

Note: It is necessary to insert an XLR termination plug (with 120 Ohm) in the last fixture in order to ensure proper transmission on the DMX data link.

Display Off after 30 seconds

When no button is pressed for 30 seconds, the display will turn off.

To light up the display, you have to press the MENU, UP, DOWN, ENTER button or press the DIMMER or ZOOM control. Once you have pressed the button, the display will light up.

Menu Overview



Main Menu Options

ADDR	DMX-512 Mode
RUN	Run Mode
STAT	Zoom/Dimmer settings
CAL	White color calibration
SET	General settings
MOTR	Motor reset

1. DMX-512 Mode

In this mode you can set the DMX starting address.

- 01) While in the main menu, press the **UP/DOWN** buttons until the display shows **ADDR**.
- 02) Press the **ENTER** button to open the menu.
- 03) Press the **UP/DOWN** buttons to set the desired DMX starting address. The adjustment range is between **0001** ^{Up/Down} **0512**.

2. Run Mode

In this mode you can set the device as a master or slave.

- 01) While in the main menu, press the **UP/DOWN** buttons until the display shows **RUN**.
- 02) Press the **ENTER** button to open the menu.
- 03) Press the **UP/DOWN** buttons to toggle between the 4 options:
 - DMX** Master mode (DMX-controlled)
 - SLAV** Slave mode
 - IMMR** Triac dimmer mode
 - SENS** Voltage-sensitive mode
- 04) If the display shows **DMX**, the Performer will be classified as a master device and will utilize the DMX protocol to determine its performance.
- 05) If the display shows **SLAV**, the Performer will be classified as a slave device and will react the same as the master device.
- 06) If the display shows **IMMR** and the device is connected to a triac, DMX will not function and dimming will be possible only by means of your triac.
- 07) When the display shows **SENS**, two situations may occur:
 - When the power supply is operating at the voltage higher by 80% than the nominal voltage and a DMX signal is received, the Performer will be controlled by DMX.
 - When the power supply is operating at the voltage lower by 80% than the nominal voltage and there is not any DMX signal, the Performer will switch to Triac mode

3. Zoom/Dimmer settings

You can enter the Zoom/Dimmer settings by **pressing** the ZOOM/DIMMER controls (on the control panel **(37)**) twice. You can also gain access by following the instructions below.

- 01) While in the main menu, press the **UP/DOWN** buttons until the display shows **STAT**.
- 02) Press the **ENTER** button to open the menu.
- 03) Press the **UP/DOWN** buttons to toggle between the 2 options:
ZOOM Zoom
DIM Dimmer
- 04) When the display shows **ZOOM**, press the **ENTER** button to open the zoom settings.
- 05) Press the **UP/DOWN** buttons (or turn the ZOOM control on the control panel **(37)**) to increase/decrease the zoom factor. The adjustment range is between **Z000** ^{Up/Down} **Z100**, from small to big.
- 06) When the display shows **DIM**, press the **ENTER** button to open the dimmer intensity settings.
- 07) Press the **UP/DOWN** buttons (or turn the DIMMER control on the control panel **(37)**) to increase/decrease the dimmer intensity. The adjustment range is between **D000** ^{Up/Down} **D100**, from dark to brightest.

4. White color calibration

- 01) While in the main menu, press the **UP/DOWN** buttons until the display shows **CAL**.
- 02) Press the **ENTER** button to open the menu.
- 03) If the display shows **---**, you need to insert a **key combination** which will **unlock the menu**.
- 04) **Insert** the key combination by **pressing the buttons** in the **following order: UP, DOWN, UP, DOWN, ENTER**. The display will show **CALZ**.
- 05) Press the **ENTER** button to proceed to zoom range selection.
- 06) Press the **UP/DOWN** buttons to choose one of the 2 options: **POS1** or **POS2**.
- 07) Once you have chosen one of the 2 zoom ranges, press the **ENTER** button to open its submenu.
- 08) Press the **UP/DOWN** buttons to increase/decrease the zoom factor. The adjustment range is between **Z000** ^{Up/Down} **Z255**, from small to big.

5. General settings

- 01) While in the main menu, press the **UP/DOWN** buttons until the display shows **SET**.
- 02) Press the **ENTER** button to open the menu.
- 03) If the display shows **LOCK**, you need to insert a **key combination** which will **unlock the menu**.
- 04) **Insert** the key combination by **pressing the buttons** in the **following order: UP, DOWN, UP, DOWN, ENTER**.
- 05) Press the **UP/DOWN** buttons to toggle between the following options:
 - CURV** Dimming curve settings
 - DIMX** Dimmer speed
 - KEY** Safety key
 - MCON** DMX data transfer
 - PERF** Performance settings
 - ZOOM** Zoom range settings
 - DERR** Save DMX/Blackout
 - SLCK** Settings menu safety lock
 - PERS** DMX channel modes
 - REST** Reset settings

5.1. Dimming curve settings

- 01) When the display shows **CURV**, press the **ENTER** button to open the menu.
- 02) Press the **UP/DOWN** buttons to choose the desired dimming curve out of the 4 available options:

Dimming curves

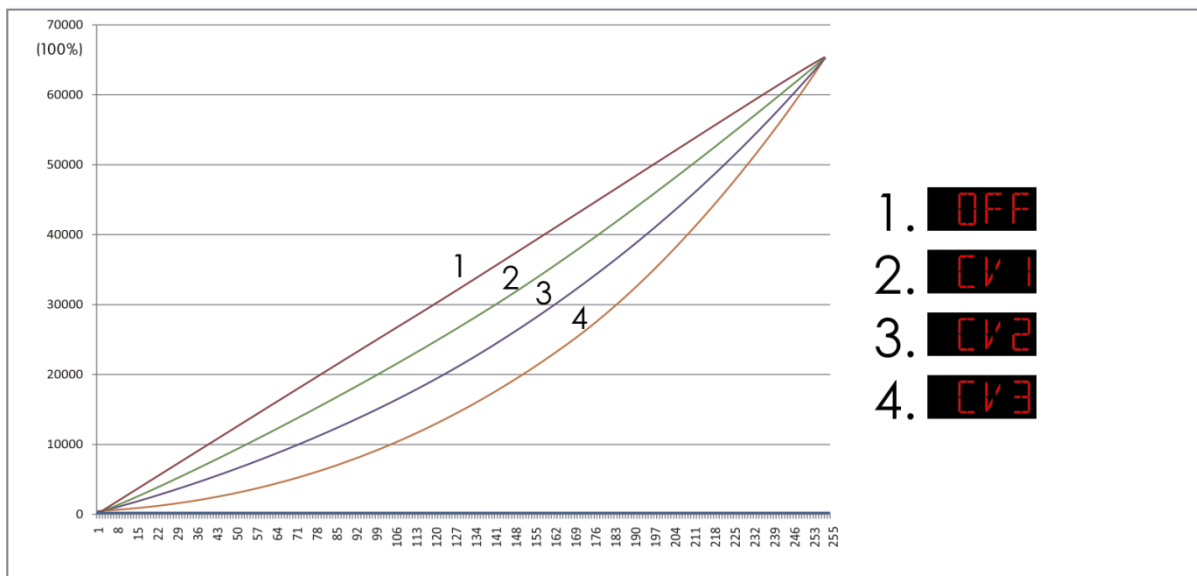

5.2. Dimmer speed

- 01) When the display shows **DIMX**, press the **ENTER** button to open the menu.
- 02) Press the **UP/DOWN** buttons to choose one of the 5 options:

OFF

OFF

DIM1 ^{Up/Down} **DIM4**

Dimmer speed, from fast to slow

5.3. Safety key

- 01) When the display shows **KEY**, press the **ENTER** button to open the menu.
- 02) Press the **UP/DOWN** buttons to toggle between **OFF** ^{Up/Down} **ON** to deactivate/activate the safety lock.
- 03) When the option is **active**, you will need to insert the safety key combination every time the display turns off.

5.4. DMX data transfer

- 01) When the display shows **MCON**, press the **ENTER** button to open the menu.
- 02) Press the **UP/DOWN** buttons to toggle between the 2 options:

SELF

DMX data transfer OFF

MAST

DMX data transfer ON

- 03) If the display shows **SELF**, the Performer will not send DMX data to the other connected devices.
- 04) If the display shows **MAST**, the Performer will send DMX data to the other connected devices.

5.5. Performance settings

- 01) When the display shows **PERF**, press the **ENTER** button to open the menu.
- 02) Press the **UP/DOWN** buttons to toggle between the 3 modes:

LIVE

Default mode. The Performer provides a compromise between output quality and noise level.

POWR

Output-oriented mode. The device does not offer any consideration for noise level and operates at full power.

STDO

Noise level-oriented mode. The Performer emits little noise and operates at moderate power level.

5.6. Zoom range settings

- 01) When the display shows **ZOOM**, press the **ENTER** button to open the menu.
- 02) Press the **UP/DOWN** buttons to toggle between the following 3 options:

BASE

Zoom, basic position

POS1

Zoom, 1st position

POS2

Zoom, 2nd position

5.7. Save DMX/Blackout

- 01) When the display shows **DERR**, press the **ENTER** button to open the menu.
- 02) Press the **UP/DOWN** buttons to toggle between the 2 options:
BLAK Blackout
SAVE DMX data save

- 03) If the display shows **BLAK**, the Performer will blackout the output, in case of the DMX signal error.
- 04) If the display shows **SAVE**, the Performer will fall back on the last working DMX signal, which will ensure undisrupted performance.

5.8. Settings lock

- 01) When the display shows **SLCK**, press the **ENTER** button to open the menu.
- 02) Press the **UP/DOWN** buttons to toggle between **OFF** ^{Up/Down} **ON**.
- 03) When the display shows **ON**, you will need to insert the password (press **UP, DOWN, UP, DOWN, ENTER**) to enter Settings menu.

5.9. DMX channel modes

- 01) When the display shows **PERS**, press the **ENTER** button to open the menu.
- 02) Press the **UP/DOWN** buttons to toggle between the 3 channel modes:
UND 1-channel mode
DOS 2-channel mode
STIP 5-channel mode

5.10. Reset settings

- 01) When the display shows **REST**, press the **ENTER** button to enter the menu. The display will show **REST**.
- 02) Insert the safety key combination by pressing the buttons in the following order: **UP, DOWN, UP, DOWN, ENTER**.
- 03) The display will promptly show **OK** and the settings will have been reset.

6. Motor reset

- 01) While in the main menu, press the **UP/DOWN** buttons until the display shows **MOTR**.
- 02) Press the **UP/DOWN** buttons to choose between Yes and No.
- 03) If the display shows **YES**, press the **ENTER** button.
- 04) The device will now perform the motor reset.

DMX Channels

1 Channel

Channel 1 – Dimmer

0-255 Gradual dimmer adjustment, 0-100%

2 Channels

Channel 1 – Dimmer

0-255 Gradual dimmer adjustment, 0-100%

Channel 2 – Fine dimmer

0-255 Fine dimmer adjustment

5 Channels

Channel 1 – Dimmer

0-255 Gradual dimmer adjustment, 0-100%

Channel 2 – Fine dimmer

0-255 Fine dimmer adjustment

Channel 3 – Strobe

0-9 Strobe OFF

10-99 Strobe ON, from low to high frequency

100-109 Strobe OFF

110-179 Pulse strobe ON, from low to high frequency

180-189 Strobe OFF

190-255 Random strobe, from low to high frequency

Channel 4 – Zoom

0-255 Gradual zoom adjustment, from small to big

Channel 5 – Motor reset

0-200 Not functional

201-220 Motor reset

221-255 Not functional

Cleaning

Please follow the next recommendations when cleaning and inspecting lenses and reflectors:

Do not use glass or window type cleaners on lenses (glass or polymer) or reflectors.

Do not use abrasive materials such as steel wool.

Replace lenses if they contain visible damage (cracks or deep scratches) which that may impair their effectiveness.

Cleaning the glass lens

- 01) Remove the front cap **(01)**.
- 02) Dampen a clean lint-free cloth with vinegar or household ammonia. You may also use water, but it will leave spots that can be removed by gently polishing the front lens **(02)** with a clean and dry cloth.
- 03) Starting from the center, gently wipe the lens.
- 04) Re-attach the front cap.

Maintenance

The operator has to make sure that safety-related and machine-technical installations are to be inspected by an expert after every year in the course of an acceptance test.

The operator has to make sure that safety-related and machine-technical installations are to be inspected by a skilled person once a year.

The following points have to be considered during the inspection:

- 01) All screws used for installing the device or parts of the device have to be tightly connected and must not be corroded.
- 02) There may not be any deformations on housings, fixations and installation spots.
- 03) Mechanically moving parts like axles, eyes and others may not show any traces of wearing.
- 04) The electric power supply cables must not show any damages or material fatigue.

The Performer 2000 Fresnel DDT MKII requires almost no maintenance. However, you should keep the unit clean.

Otherwise, the fixture's light output will be significantly reduced. Disconnect the mains power supply, and then wipe the cover with a damp cloth. Do not immerse in liquid. Wipe lens clean with glass cleaner and a soft cloth. Do not use alcohol or solvents.

The front lens will require weekly cleaning, as smoke-fluid tends to build up residues, reducing the light-output very quickly.

Please clean internal components once a year with a light brush and vacuum cleaner.

Keep connections clean. Disconnect electric power, and then wipe the DMX and audio connections with a damp cloth. Make sure connections are thoroughly dry before linking equipment or supplying electric power.

Replacing the Fuse

Power surges, short-circuit or inappropriate electrical power supply may cause a fuse to burn out. If the fuse burns out, the product will not function whatsoever. If this happens, follow the directions below:

- 01) Unplug the unit from electric power source.
- 02) Insert a flat-head screwdriver into a slot in the fuse cover. Turn the screwdriver to the left, at the same time gently push a bit (Turn and Push). The fuse will come out.
- 03) Remove the used fuse. If brown or unclear, it is burned out.
- 04) Insert the replacement fuse into the holder where the old fuse was. Reinsert the fuse cover. Be sure to use a fuse of the same type and specification. See the product specification label for details.

Troubleshooting

This troubleshooting guide is meant to help solve simple problems.

If a problem occurs, carry out the steps below in sequence until a solution is found. Once the unit operates properly, do not carry out following steps.

No Light

If the light effect does not operate properly, refer servicing to a technician.

Suspect three potential problem areas as: the power supply, the LEDs, the fuse.

- 01) Power supply. Check if the unit is plugged into an appropriate power supply.
- 02) The LEDs. Return the Performer to your Showtec dealer.
- 03) The fuse. Replace the fuse. See page 24 for replacing the fuse.
- 04) If all of the above appears to be O.K., plug the unit in again.
- 05) If you are unable to determine the cause of the problem, do not open the Performer, as this may damage the unit and the warranty will become void.
- 06) Return the device to your Showtec dealer.

No Response to DMX

Suspect the DMX cable or connectors, a controller malfunction, a light effect DMX card malfunction.

- 01) Check the DMX setting. Make sure that DMX addresses are correct.
- 02) Check the DMX cable: Unplug the unit; change the DMX cable; then reconnect to electrical power. Try your DMX control again.
- 03) Determine whether the controller or light effect is at fault. Does the controller operate properly with other DMX products? If not, take the controller in for repair. If so, take the DMX cable and the light effect to a qualified technician.

Problem	Probable cause(s)	Solution
One or more fixtures do not function at all	No power to the fixture	<ul style="list-style-type: none"> Check if power is switched on and cables are plugged in
	Primary fuse blown	<ul style="list-style-type: none"> Replace fuse
Fixtures reset correctly, but all respond erratically or not at all to the controller	The controller is not connected.	<ul style="list-style-type: none"> Connect controller.
	3-pin/5-pin XLR Out of the controller does not match XLR Out of the first fixture on the link (i.e. signal is reversed)	<ul style="list-style-type: none"> Install a phase reversing cable between the controller and the first fixture on the link
Fixtures reset correctly, but some respond erratically or not at all to the controller	Poor data quality	<ul style="list-style-type: none"> Check data quality. If much lower than 100 percent, the problem may be a bad data link connection, poor quality or broken cables, missing termination plug, or a defective fixture disturbing the link
	Bad data link connection	<ul style="list-style-type: none"> Inspect connections and cables. Correct poor connections. Repair or replace damaged cables
	Data link not terminated with 120 Ohm termination plug	<ul style="list-style-type: none"> Insert termination plug in output jack of the last fixture on the link
	Incorrect addressing of the fixtures	<ul style="list-style-type: none"> Check address setting
	One of the fixtures is defective and disturbs data transmission on the link	<ul style="list-style-type: none"> Bypass one fixture at a time until normal operation is restored: unplug both connectors and connect them directly together. Have the defective fixture serviced by a qualified technician
	3-pin/5-pin XLR Out on the fixtures does not match (pins 2 and 3 reversed)	<ul style="list-style-type: none"> Install a phase-reversing cable between the fixtures or swap pin 2 and 3 in the fixture that behaves erratically
No light or lamp cuts out intermittently	Fixture is too hot	<ul style="list-style-type: none"> Allow the fixture to cool down Clean the fan Make sure air vents in control panel and the front lens are not blocked Turn up the air conditioning
	LEDs damaged	<ul style="list-style-type: none"> Disconnect the fixture and return it to your dealer
	The power supply settings do not match local AC voltage and frequency	<ul style="list-style-type: none"> Disconnect fixture. Check settings and correct if necessary

Product Specifications

Model:	Showtec Performer 2000 Fresnel DDT MKII
Input voltage:	100-240V AC, 60/50Hz
Power consumption:	180W (full output)
DMX linking:	30pcs
Fuse:	T3,15AL/250V
Dimensions:	255 x 380 x 388 mm (LxWxH)
Weight:	6,8 kg
Operating and Programming:	
Signal pin OUT:	Pin 1 (earth), pin 2 (-), pin 3 (+)
DMX Mode:	1, 2, 5 channels
Signal input:	3-pin/5-pin XLR IN
Signal output:	3-pin/5-pin XLR OUT
Electro-mechanical effects:	
Light source:	1x 200W CITIZEN LED
Light output:	6370 Lumen
Zoom:	13-41°
Dimmer:	0-100%
Dimming curve:	Dimm4 technology, 4 presets
Strobe:	0-20Hz
Peak intensity:	100333cd
Color rendering:	>90Ra
Color temperature:	3200K
Refresh rate:	600Hz-25000Hz
Housing:	Die-cast aluminium & flame-retardant plastic
DMX control:	via standard DMX-controller
Onboard:	LED display for easy setup
Control:	Stand-alone, Master/Slave, DMX-512
Connections:	3-pin/5-pin XLR signal connectors IN/OUT, PowerCON power connectors IN/OUT
IP rating:	IP20
Cooling:	Convection
Max. ambient temperature t_a :	40°C
Max. housing temperature t_b :	80°C
Minimum distance:	
Minimum distance from flammable surfaces:	0,5 m
Minimum distance to lighted object:	1 m

Design and product specifications are subject to change without prior notice.



Website: www.Showtec.info

Email: service@highlite.nl

Dimensions

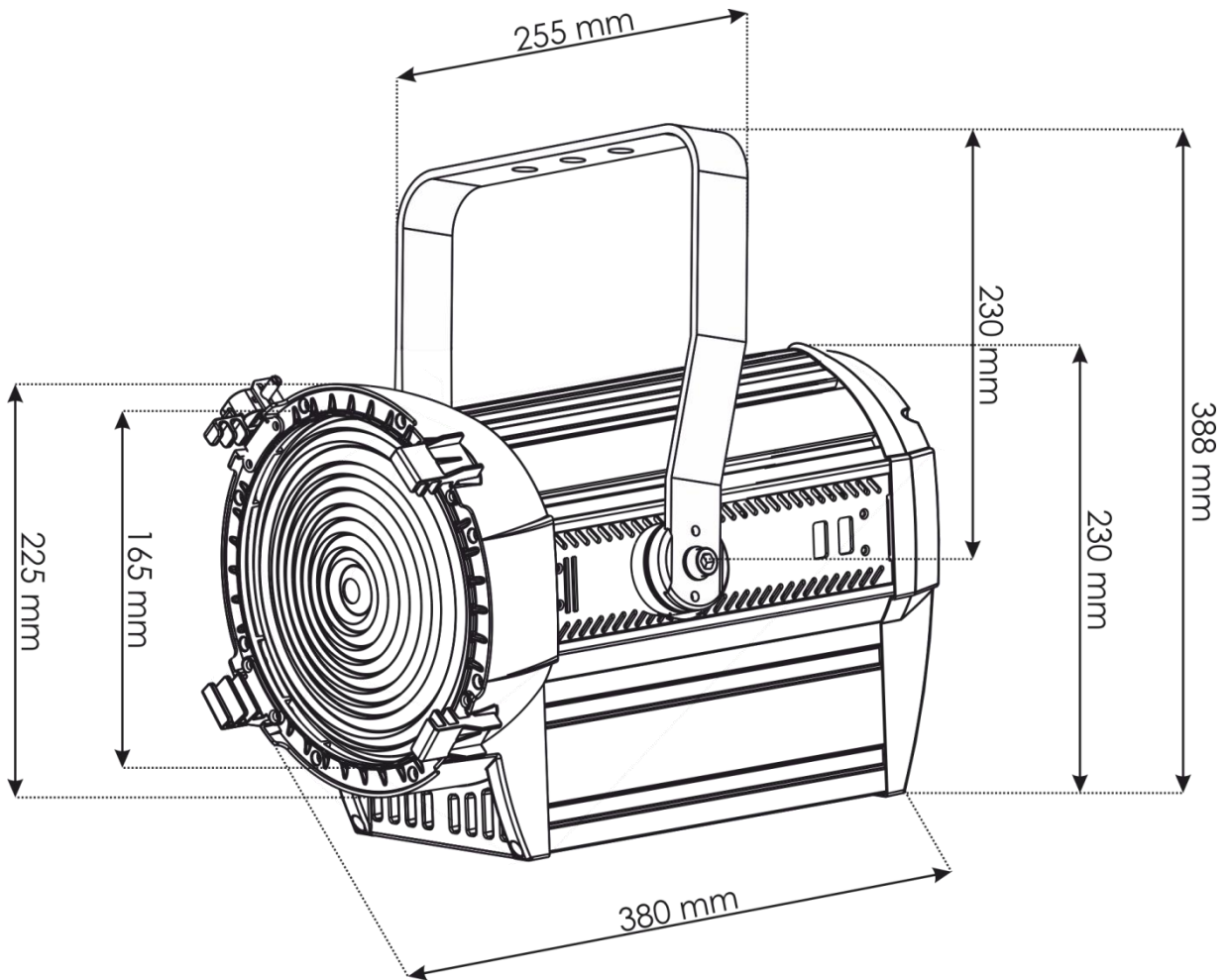



©2017 Showtec